

Owners Installation, Operation, and Safety Manual



Series **700V**

Fuel Transfer Pump

Series 700V – 115 and 230 VOLT AC

Models FR700V, FR701V, FR710V, & FR711V

Table of Contents

Table of Contents.....	2
Thank You!.....	2
About This Manual	2
Safety Information.....	3
Installation.....	3
Anti-Siphon Device	7
Electrical Wiring	8
Wiring Procedure	8
Operating Instructions.....	9
Pad Locking.....	9
Trouble Shooting.....	9
Accessories.....	11
Safety Testing Approvals	11
Replacement Parts Information.....	12
FR700V / FR701V / FR710V / FR711V Parts List.....	12
Tuthill Product Warranty	14
Fluid Compatibility.....	14
Technical Information / Specifications.....	15
700E Model Information.....	16

Thank You!

Thank you for your purchase of the Fill-Rite 700V series pump! Your Fill-Rite product comes with over 80 years of pump manufacturing experience behind it, providing you the value that comes with superior performance, user friendly design, long service life, and solid, simple engineering. Experience that gives you peace of mind.

Rest Easy – It’s Tuthill!

About This Manual

From initial concept and design through its final production, your Fill-Rite pump is built to give you years of trouble free use. To insure it provides that service, **it is critical that you read this entire manual prior to attempting to install or operate your new pump.** Become familiar with the terms and diagrams, and pay close attention to the highlighted areas with the following labels:



WARNING! Emphasizes an area in which personal injury or even death could result from failure to follow instructions properly. Mechanical damage may also occur.



IMPORTANT! These boxes contain information that illustrates a point that may save time or may be key to proper operation, or clarifies a step.



CAUTION! Failure to observe a “Caution” can cause damage to the equipment.

At Tuthill, your satisfaction with our products is paramount to us. If you have questions or need assistance with your product, please contact us at 1-800-634-2695 (M-F 8 AM–5 PM ET).

Safety Information



WARNING! Electrical wiring should be performed **ONLY** by a licensed electrician in compliance with local, state, and national electrical code NEC/ANSI/NFPA 70, NFPA30, and NFPA 30A, as appropriate to the intended use of the pump. Threaded rigid conduit, sealed fittings, and conductor seal should be used. The pump must be properly grounded. Improper installation or use of this pump can result in serious bodily injury, or death!



WARNING! To insure safe and proper operation of your equipment, it is critical to read and adhere to all of the following safety warnings and precautions. Improper installation or use of this product can cause serious bodily injury or death!

- 1) **NEVER** smoke near the pump, or use the pump near open flames when pumping a flammable liquid! Fire can result!
- 2) A Fill-Rite Filter should be used on the pump outlet to insure no foreign material is transferred to the fuel tank.
- 3) Threaded pipe joints and connections should be sealed with the appropriate sealant or sealant tape to minimize the possibility of leaks.
- 4) Storage tanks should be securely anchored to prevent shifting or tipping when full or empty.
- 5) To minimize static electricity build up, use only static wire conductive hose when pumping flammable fluids, and keep the fill nozzle in contact with the container being filled during the filling process.
- 6) The pump motor is equipped with thermal overload protection; if overheated, the motor will shut off to prevent damage to the windings. If this happens, **TURN THE PUMP OFF!** When the motor cools, it will restart without warning if the power is on.



WARNING! This product shall not be used to transfer fluids into any type of aircraft.



WARNING! This product is not suited for use with fluids intended for human consumption or fluids containing water.

Installation

The Fill-Rite Series 700V pump is designed to offer several different mounting configurations. It can be mounted on a skid tank using the tank adapter supplied with the pump (see attached diagrams), direct mounted to the top of an underground tank, or mounted on a concrete island using an optional pedestal adapter (available through your Fill-Rite distributor). Regardless of mounting style, all tanks must be properly vented, and skid tank installations should employ an anti-siphon device.

The 700V series pump has a built in check valve with pressure relief to reduce unsafe excess pressure from thermal expansion of the fluid. It also features an integral bypass valve to help minimize wear when the pump is operating with the nozzle closed.



WARNING! In "Skid Tank" applications, be sure the tank is properly secured so it cannot shift or move when the tank is empty or full.



WARNING! Threaded pipe joints and connections should be sealed with the appropriate sealant or sealant tape to minimize the possibility of leaks.



CAUTION! A pressure retaining fill cap can be used to reduce fuel loss through evaporation, but note that it may reduce the flow rate.



CAUTION! Do not use additional check valves or foot valves unless they have a proper pressure relief valve built into them. Note that additional check valves will reduce rate of flow.

Typical Skid Tank Installation

Materials:

- 1-1/4" pipe cut to a length that will terminate at least 3" from the bottom of the tank when screwed into the tank adapter with the tank adapter screwed into the tank flange (see **SKID TANK INSTALLATION** diagram).
- Threaded pipe joint sealant appropriate for application.

Installation Procedure:

- 1) Thread the 1-1/4" pipe into the tank adapter. Seal threads liquid tight with appropriate thread sealant.
- 2) Screw the tank adapter into the tank flange; seal threads liquid tight with appropriate thread sealant.
- 3) Mount the pump on the adapter; seal threads liquid tight with appropriate thread sealant.
- 4) Fill-Rite recommends installation of our Anti-Siphon Device (see page 7 for detailed information).

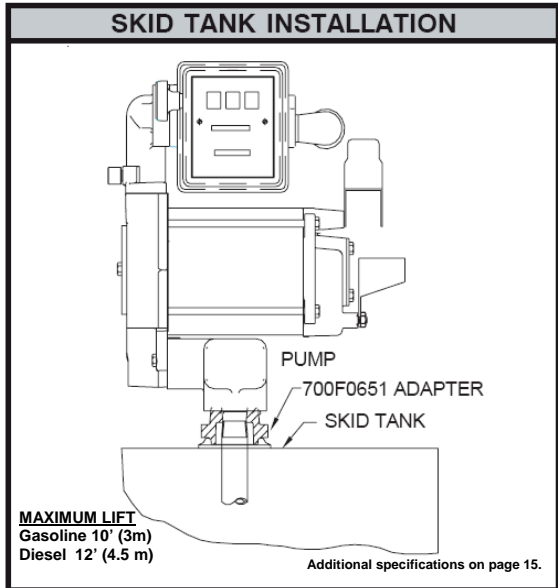

WARNING! Threaded pipe joints and connections should be sealed with the appropriate sealant or sealant tape to minimize the possibility of leaks.

Typical Direct Mount Installation (to underground tank)

Materials:

- 2" pipe cut to length and threaded at both ends that will extend approximately 31" above the ground when installed in the tank flange.
- 1-1/4" pipe cut to a length that will terminate at least 3" from the bottom of the tank when screwed into the tank adapter screwed into the tank flange (see **DIRECT MOUNTING INSTALLATION** diagram).
- Threaded pipe joint sealant appropriate for application.

Installation Procedure:

- 1) Install the 2" pipe in the tank flange; seal threads liquid tight with appropriate sealant.
- 2) Screw a 2" standard pipe coupling onto the top of the pipe; seal threads liquid tight with appropriate sealant.
- 3) Screw the 1-1/4" pipe into the tank adapter. Seal threads liquid tight with appropriate sealant.
- 4) Screw the tank adapter into the 2" coupling; seal threads liquid tight with appropriate sealant.
- 5) Mount pump on tank adapter; seal threads liquid tight with appropriate sealant.

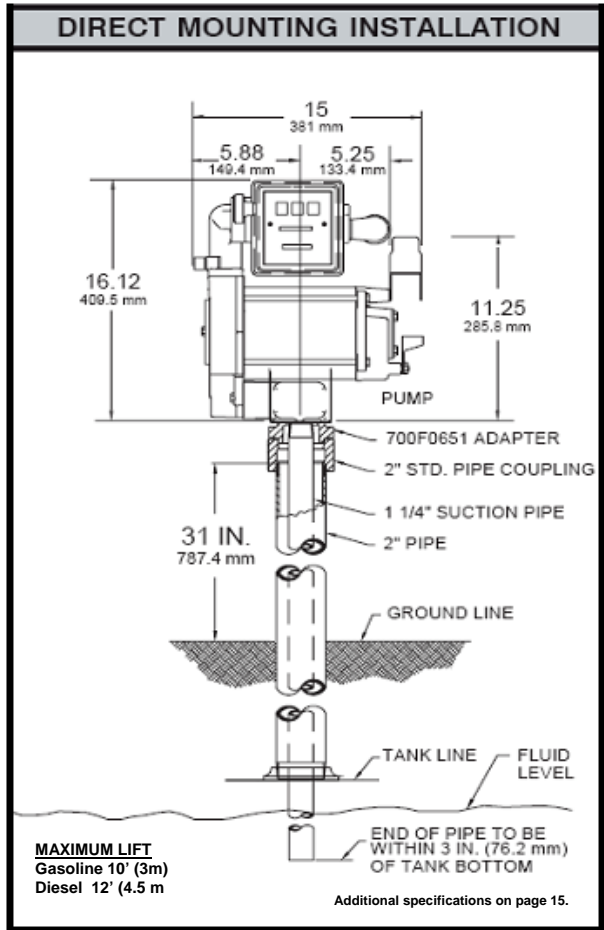

WARNING! Threaded pipe joints and connections should be sealed with the appropriate sealant or sealant tape to minimize the possibility of leaks.

Typical “Island” Installation

Materials:

- 1-1/4” threaded suction pipe, cut to extend 32-1/2” above the island.
- FRPA125 Pedestal Kit (includes Pedestal Pipe, Base, & Coupler).
- Threaded pipe joint sealant appropriate for application.

Installation Procedure:

- 1) Remove the coupler from the pedestal pipe by loosening the set screws.
- 2) Slip the pedestal pipe / pump base assembly over the 1-1/4” suction pipe.
- 3) Loosen the screws in the pedestal base to allow the pedestal pipe to slide down exposing the end of the suction pipe.
- 4) Screw the coupler onto the suction pipe; seal threads liquid tight with appropriate thread sealant.
- 5) Slide the pedestal pipe into the coupler and tighten the set screws.
- 6) Tighten the screws in the pedestal base.
- 7) Mount the pump on the coupler seal threads liquid tight with appropriate thread sealant.

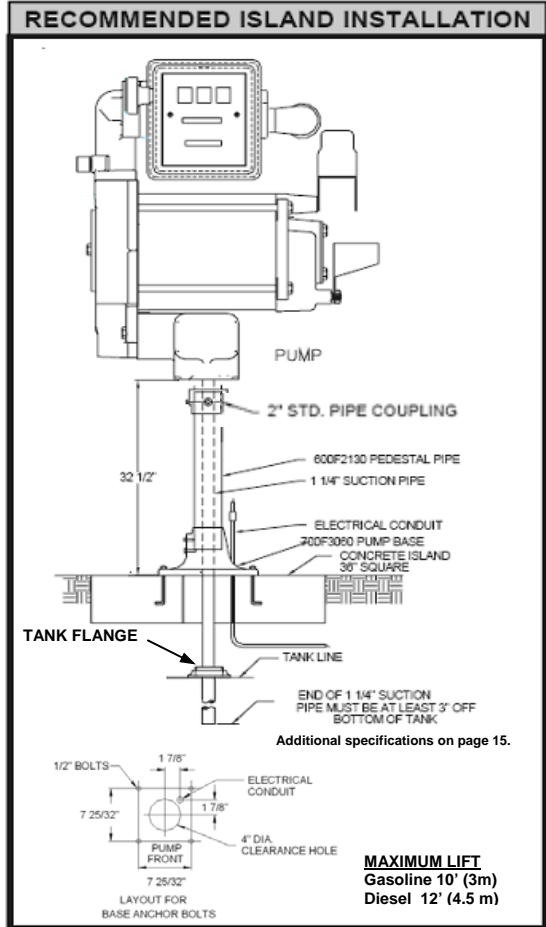

WARNING! Threaded pipe joints and connections should be sealed with the appropriate sealant or sealant tape to minimize the possibility of leaks.

Anti-Siphon Device

Your 700V Series pump comes from the factory anti-siphon ready, easily allowing you to install an anti-siphon tube back to the tank. An anti-siphon device (sometimes called a vacuum breaker) is important because it will break a liquid siphon if there is an open nozzle or a leaking hose below the fluid level in the tank when the pump is turned off. Fill-Rite recommends that an anti-siphon tube be installed from the pump outlet back to the vapor space in the tank using kit # KIT700AS.



The accompanying illustration shows where and how to install the tube so that it terminates in the vapor space at the top of the tank. The tube must terminate in the vapor space; if it terminates below the fluid level in the tank, it will not prevent siphoning. It is also very important that there are no liquid traps in the tubing. The tubing must have a continuous slope from the pump down to the tank, and can be connected into any opening in the top of the tank if the tank adapter is not used. Use reducer bushings as required for proper fit and seal.

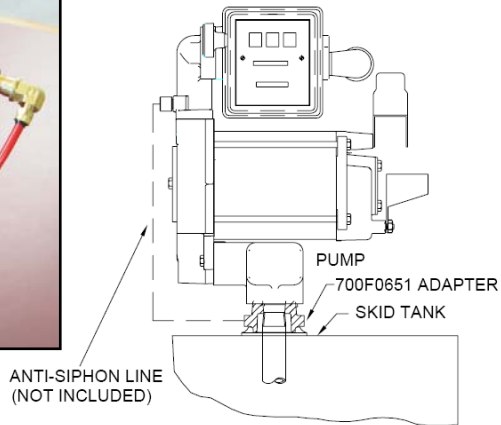

We recommend using the anti-siphon tank adapter with a 1/4 NPT opening in the side of the hex portion. This opening terminates in the vapor space of the tank. Make a liquid-tight connection using the appropriate sealant from the adapter to the anti-siphon outlet using a minimum of 1/4 metal tubing that is compatible with whatever liquid is being pumped. If the anti-siphon tank adapter is being used and the 1/4 NPT opening is not used for the tubing, leave the factory installed plug in place.

Fill-Rite offers Anti-Siphon kit # KIT700AS (available through your Fill-Rite distributor). This kit contains the necessary fittings and tubing to complete the installation as pictured in this section.



WARNING! Threaded pipe joints and connections should be sealed with the appropriate sealant or sealant tape to minimize the possibility of leaks.

Electrical Wiring



WARNING! Electrical wiring should be performed **ONLY** by a licensed electrician in compliance with local, state, and national electrical code NEC/ANSI/NFPA 70, NFPA30, and NFPA 30A, as appropriate to the intended use of the pump. Threaded rigid conduit, sealed fittings, and conductor seal should be used. The pump must be properly grounded. Improper installation or use of this pump can result in serious bodily injury, or death!



CAUTION! All pumps should be operated at the Rated Nameplate Voltage. Power should be supplied to the pump from a dedicated 20 amp circuit breaker. No other equipment should be powered by this circuit. Wiring must be of sufficient size to carry the correct current for the pump. Voltage drop will vary with distance to pump and size of wire; refer to the National Electrical Code (NEC), or local codes, for Voltage Drop Compensation to be sure you are using the correct size wire for your application.

Wiring Procedure



WARNING! The “AUX.” wire **IS A LIVE WIRE** when the switch is on! The “AUX” lead wire is insulated and enclosed when shipped. **DO NOT** connect this wire without first verifying the “ON” line voltage of the wire for compatibility with the equipment to be installed. Maximum amperage on this wire is 1 amp. The “AUX” wire must be insulated and enclosed in the junction box if not used.

- 1) Remove the junction box cover and straighten the wires to make sure the stripped wire ends are accessible outside the junction box.
- 2) Connect the pump wires to the power supply lines according to the diagram. Be certain to properly insulate the connections with the appropriate wire nuts or other connectors. Note that the ground wire **MUST** be connected.
- 3) Fold the wires back into the junction box and replace the cover, making sure the cover gasket is in place.



IMPORTANT! Be certain the gasket for the cover is in place, and the screws draw the cover down tight over the junction box. There must be no gap between the junction box and its cover.

115 VOLT WIRING DIAGRAM

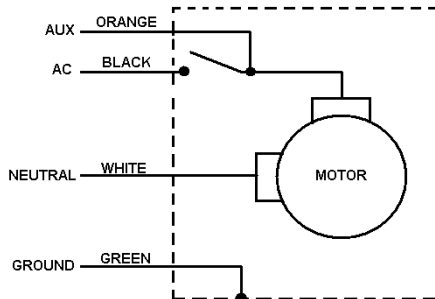

230 VOLT WIRING DIAGRAM (G & E Models only; refer to motor tag to determine model and voltage.)

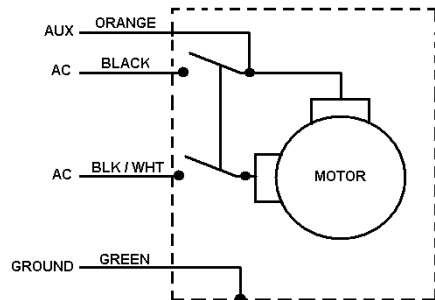

Operating Instructions

- 1) Reset Meter to "0" (if applicable).
- 2) Remove dispensing nozzle from nozzle boot.
- 3) Move the switch lever to the "ON" position to power the pump.
- 4) Insert the dispensing nozzle into the container to be filled.
- 5) Operate the nozzle to dispense fluid; release nozzle when the desired amount of fluid has been dispensed.
- 6) Move switch lever to the "OFF" position to stop the pump.
- 7) Remove the dispensing nozzle from the container and store it in the nozzle boot.

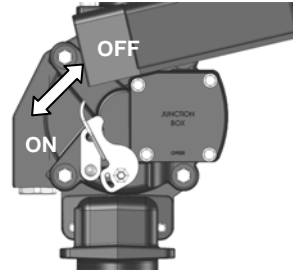

CAUTION! Always keep the nozzle in contact with the container being filled **during the filling process** to minimize the possibility of static electricity build up.

Pad Locking

Your Fill-Rite pump nozzle can be pad locked for added security. With the pump turned off, and the nozzle in the stored position, a pad lock can be inserted through the locking link and the nozzle handle opening. This configuration prevents the nozzle from being removed from the nozzle cover.

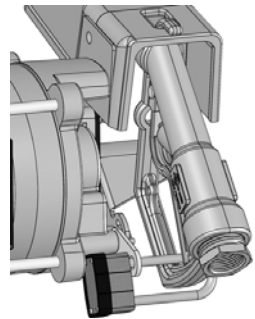

Trouble Shooting

The following Trouble Shooting guide is provided to offer basic diagnostic assistance in the event you encounter abnormal service from your Tuthill product.



WARNING! DO NOT open or attempt to repair the motor on your Tuthill pump. Return it to the place of purchase for service. **Opening the motor case can compromise the integrity of the Explosion Proof construction and will void any existing warranty and certification (UL listing).**

If you have questions regarding installing, operating, or servicing your product, please feel free to contact our Customer Service Department at 1-800-634-2695 (M-F 8 AM-5 PM ET). You can also reach us on the World Wide Web at "www.tuthill.com".



WARNING! Be certain all power to the pump is turned off prior to performing any service or maintenance.

Symptom	Cause	Cure
Pump won't prime.	1. Suction line problem.	Check for leaks in suction line
	2. Bypass valve open.	Remove and inspect valve; must move freely & be free of debris.
	3. Vanes sticking.	Check vanes and slots for nicks, burrs and wear.*
	5. Excessive rotor or vane wear.	Inspect rotor & vanes for excessive wear or damage; replace if necessary.*
	6. Outlet blocked.	Check pump outlet, hose, nozzle & filter for blockage.
	7. Vapor Lock	Reduce vertical and horizontal distance from pump to liquid; remove automatic nozzle.
Low capacity.	1. Excessive dirt in screen.	Remove and clean screen.
	2. Suction line problem.	Check suction line for leaks or restrictions; it may be too small, too long or not airtight.
	3. Bypass valve sticking.	Remove and inspect valve; must move freely & be free of debris.
	4. Vanes sticking.	Check vanes and slots for wear.
	5. Excessive rotor or vane wear.	Inspect rotor & vanes for excessive wear or damage; replace if necessary.*
	6. Hose or nozzle damage.	Replace hose or nozzle.
	7. Plugged filter.	Replace filter.
	8. Low fluid level.	Fill tank.
Pump runs slowly.	1. Incorrect voltage.	Check incoming line voltage while pump is running.
	2. Vanes sticking.	Inspect vanes and slots for nicks, burrs and wear.*
	3. Wiring problem.	Check for loose connections.
	4. Motor problem.	Return to place of purchase.
Motor stalls.	1. Bypass valve sticking.	Remove and inspect valve; must move freely & be free of debris.
	2. Low voltage.	Check incoming line voltage while pump is running.
	3. Excessive rotor or vane wear.	Check rotor & vanes for excessive wear or damage.*
	4. Debris in pump cavity.	Clean debris from pump cavity.
Motor overheats.	1. Pumping high viscosity fluids.	These fluids can only be pumped for short periods of time (less than 30 minutes duty cycle).
	2. Clogged screen.	Remove and clean screen.
	3. Restricted suction pipe.	Remove and clean pipe.
	4. Motor failure.	Return to place of purchase.
	5. Pump rotor lock-up.	Clean and check pump rotor and vanes.
Motor Inoperative.	1.No power	Check incoming power.
	2. Switch failure.	Return to place of purchase.
	3. Motor failure.	Return to place of purchase.
	4. Thermal protector failure.	Return to place of purchase.
	5. Incorrect/loose wiring.	Check wiring.

Fluid leakage.	1. Bad o-ring gasket.	Check all o-ring gaskets.
	2. Dirty shaft seal.	Clean seal & seal cavity.
	3. Bad shaft seal.	Replace seal.
	4. Incompatible fluid.	Refer wetted parts list to fluid manufacturer.
	5. Loose fasteners.	Tighten fasteners.
Pump hums but will not operate.	1. Dirt in pump cavity.	Clean out pump cavity.
	2. Motor failure.	Return to place of purchase.
	3. Broken key.	Remove all debris & replace key.

Bold text indicates repairs that are not serviceable by the owner; pump must be returned to the point of purchase for repairs.

* Repairs marked with an asterisk (*) will require Repair Kit #700KTF2689. This kit includes a replacement rotor and new vanes, as well as a number of other important seals and components to complete the repair. Details of this kit are on page 13.

Accessories

A wide variety of accessories are available to help you maximize the performance of your Fill-Rite pump. Listed below are the applicable available accessories for your specific product. Please contact your authorized Fill-Rite distributor to purchase the accessories you need.

Part Number	Description	700	701	710	711
1200KTF7018	¾" Filter Kit (Particulate)	X	X		
F1810PM0	Replacement Particulate Filter Element	X	X		
1210KTF7019	¾" Filter Kit (Hydrosorb)	X	X		
F1810HM0	Replacement Hydrosorb Filter Element	X	X		
F4010PM0	1" Filter Kit (Particulate 10 micron)			X	X
F4030PM0	1" Filter Kit (Particulate 30 micron)			X	X
700ACCF7017	1" Filter Head			X	X
FRPA125	Island Pedestal Mount Kit	X	X	X	X
KIT700AS	Anti-Siphon Kit	X	X	X	X
FRH10012	1" Hose (12')			X	X
FRH10014	1" Hose (14')			X	X
700H1353	1" Hose (18')			X	X
FRH07512	¾" Hose (12')	X	X		
FRH07514	¾" Hose (14')	X	X		
FRHA07515	¾" Arctic Duty Hose (15')	X	X		
FRHA10020	1" Arctic Duty Hose (20')			X	X
N075UMN11	¾" Nozzle	X	X		
N075UUAU10	¾" Nozzle, Automatic, Unleaded Spout	X	X		
N075DAU10	¾" Nozzle, Automatic, Diesel Spout	X	X		
N100UMN11	1" Nozzle Kit, Manual, Leaded Spout			X	X
KTH1402	1" Auto Shut Off Nozzle (Ultra Hi-Flow Diesel)			X	X
N100DAU10	1" Auto Shut Off Nozzle (High Flow Diesel)			X	X
FRNA075DAU10	¾" Auto Shut Off Nozzle (Arctic Duty – Diesel)	X	X		
FRNA100DAU00	1" Auto Shut Off Nozzle (Arctic Duty – Diesel)			X	X

Safety Testing Approvals

The **Fill-Rite** line of pumps have been safety tested for compliance to the standards set forth by UL Laboratories.



Replacement Parts Information

For repairs or routine maintenance, Fill-Rite offers the parts you need. The following parts diagram and list covers all applicable parts for your Fill-Rite product. These parts can be obtained through any authorized Fill-Rite dealer. Be sure to use only genuine Fill-Rite replacement parts for your service and maintenance needs. For a list of authorized dealers, please visit our web site at "www.fillrite.com".

FR700V / FR701V / FR710V / FR711V Parts List

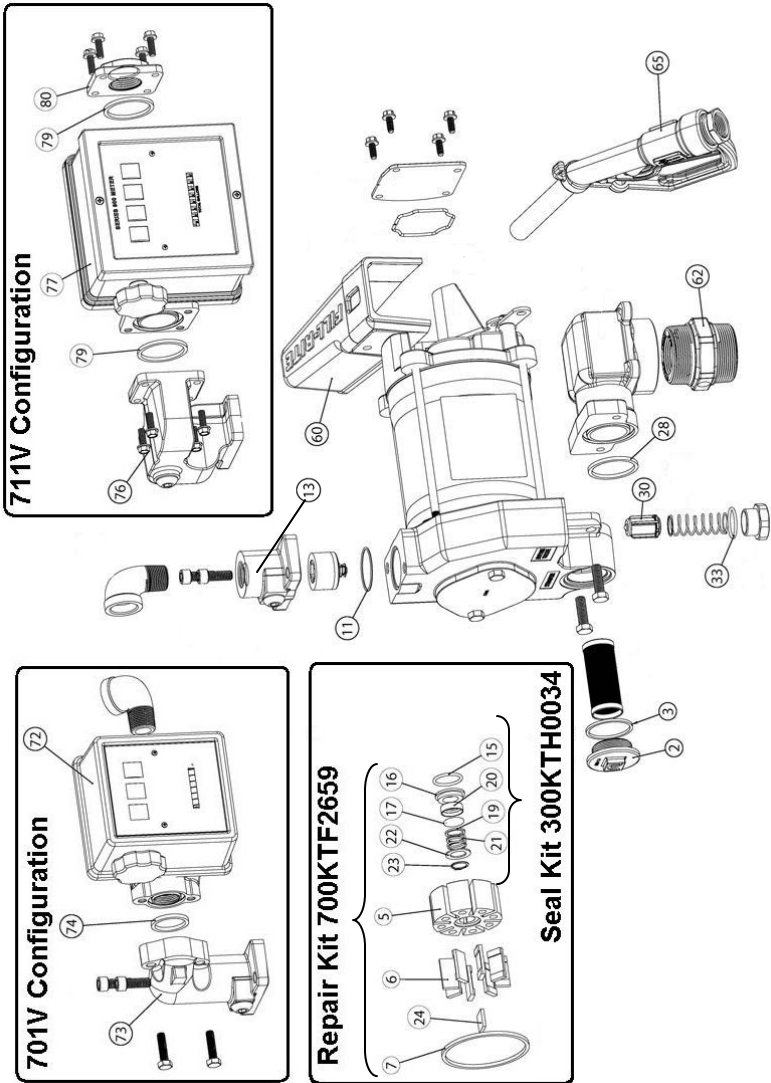

FR700V Parts

No	Part / Kit #	Description	Kit #	Qty
2	800F4360	Strainer Cover, Machined		1
3	Repair Kit 700KTF2659	Gasket, Lathe Cut, Nitrile	Seal Kit 300KTH0034	1
5		Pump Rotor, Machined		1
6		Vane, Carbon Epoxy Impregnated		8
11		O-Ring, Fluorocarbon, -030		1
7		Gasket, Lathe Cut, Nitrile		1
15		O-Ring, Fluorocarbon, -120		1
16		Inner Seal, Carbon		1
17		O-Ring, Fluorocarbon, -114		1
19		Seal Ring		1
20		Inner Seal		1
21		Spring, Seal		1
22		Washer, Shaft		1
23		Retaining Ring, External 5/8		1
24		Key, Rotor		1
28		Gasket, Lathe Cut, Nitrile		1
30		Bypass Poppet		1
33		O-Ring, Nitrile, -121		1
60	700F6673	Standard Nozzle Boot, Cast		1
62	700F0651	Machined Tank Adapter AST 2 x 1¼		1
65	N075UMN11	Nozzle Assembly		1

FR701V Parts

No.	Part Number	Description	Qty
72	807C	800 Meter (Gallon)	1
73	Kit # 701H0934	Meter Flange	1
74		Gasket, Lathe Cut, Nitrile	1
72	807CL	800 Meter (Liter)	1

FR710V Parts

No.	Part Number	Description	Qty
13	700H1321	1" Outlet Flange	1

FR711V Parts

No.	Gallon Kit Number	Description	Liter Kit Number	Qty
77	900 Meter (Gallon) Kit # 901MK300V	900 Meter (Gallons)	900 Meter (Liter) Kit # 901LMK300V	1
76		Meter Flange		1
79		Meter Gasket		2
80		1" Meter Fitting		1
77		900 Meter (Liters)		1



WARNING! DO NOT open or attempt to repair the motor on your Fill-Rite pump. Return it to the place of purchase for service. **Opening the motor can compromise the integrity of the Explosion Proof construction and will void any existing warranty and certification (UL listing).**



Tuthill Product Warranty

Tuthill Transfer Systems (“Manufacturer”) warrants each consumer buyer of its Fill-Rite products (“Buyer”) from the date of invoice or sales receipt, that goods of its manufacture (“Goods”) shall be free from defects of materials and workmanship. Duration of the warranty is as follows:

- Heavy Duty Products – Two Years
- Standard Duty Products – One Year
- Economy Duty Products – One Year
- Cabinet Pumps, Parts, and Accessories – One Year

Manufacturers sole obligation under the foregoing warranties will be limited to either – at Manufacturers option – repairing or replacing defective goods (subject to limitations hereinafter provided) or refunding the purchase price for such Goods theretofore paid by the buyer, and Buyers exclusive remedy for breach of any such warranties will be enforcement of such obligations of the Manufacturer. If the Manufacturer so requests the return of such Goods, the Goods will be redelivered to the manufacturer in accordance with Manufacturers instructions FOB Factory. The remedies contained herein shall constitute the sole recourse of the Buyer against the Manufacturer for breach of warranty. **IN NO EVENT SHALL THE MANUFACTURER’S LIABILITY FOR ANY CLAIM FOR DAMAGES ARISING OUT OF THE MANUFACTURE, SALE, DELIVERY, OR USE OF THE GOODS EXCEED THE PURCHASE PRICE.** The foregoing warranties will not extend to goods subject to misuse, neglect, accident, improper installation or maintenance, or have been repaired by anyone other than the Manufacturer or its authorized representative. **THE FOREGOING WARRANTIES ARE EXCLUSIVE AND IN LIEU OF ALL OTHER WARRANTIES OF MERCHANTABILITY, FITNESS FOR PURPOSE OF ANY OTHER TYPE, WHETHER EXPRESSED OR IMPLIED.** No person may vary the forgoing warranties or remedies, except in writing signed by a duly authorized officer of the Manufacturer. The Buyer’s acceptance of delivery of the Goods constitutes acceptance of the foregoing warranties and remedies, and all conditions and limitations thereof.

Tuthill Corporation recommends you retain your sales receipt as proof of purchase.

The following space has been provided to record important information about your pump for quick reference.

Model Number		UPC Bar Code	
Manufacture Date		Serial Number	
Date of Purchase		Purchase Location	

Fluid Compatibility

Diesel Fuel
Stoddard Solvents

Gasoline
Heptane

Kerosene
Bio-Diesel (B20 max.)

Mineral Spirits



IMPORTANT! If in doubt about compatibility of a specific fluid, contact supplier of fluid to check for any adverse reactions to the following wetted materials: **cast iron; steel; zinc plated steel; 300 series stainless steel; bronze; carbon; ceramic; polyester; fiber; fluorocarbon; buna; 400 series stainless steel; aluminum.**

Technical Information / Specifications

Design Features

- Inlet: Bung - 2" male NPT; Suction pipe- 1-1/4" female NPT.
- Outlet: 3/4" NPT (model 700 / 701) / 1" NPT (model 710 / 711).
- Cast iron pump housing: iron (composite) rotor, and carbon (composite) vanes.
- Model 700 / 701 Furnished with UL listed 3/4"x 12' hose and manual nozzle.
- Model 711 Furnished with UL listed 1" x 18' hose and automatic nozzle.
- Security: Pump equipped for padlocking (see page 9 for details).
- Thermal Overload Protection.
- Heavy Duty Switch.
- 30 Minute Duty Cycle.
- Explosion proof motor UL listed 1/3 HP motor (115 VAC-60Hz) with sealed bearings that require no maintenance.
- Integral check valve with pressure relief on outlet side prevents pressure build up and improves vertical lift.
- Easy access strainer.
- Automatic bypass valve.
- 2" threaded base for tank openings.
- Constant Amp Draw: 115VAC – 5.5 amps; 230VAC – 2.4 amps (Service Factor of 1.0).

Overall Dimensions:

Model 700V / 710V: 14.15" wide X 11.825" high x 11.5" deep.

Model 701V: 14.15" wide X 16.6" high x 11.675" deep.

Model 711V: 15.25" wide x 16.1" high x 14.1" deep.

Shipping Weight: **FR700V**: 54 lbs. / **FR701V**: 61 lbs. / **FR710V**: 54 lbs. / **FR711V**: 80 lbs.

Accessories:

- See Page 11 for a complete list of available accessories.

Performance:

- 25 psi (1.72 bar) maximum pressure @ pump outlet.
- Up to 20 gallons (75 liters) per minute.
- Maximum viscosity of fluid pumped: #2 Diesel Fuel.
- Maximum Pump Operating Temperature (ambient) 150 degrees F (66 degrees C).
- Minimum Pump Operating Temperature (ambient) – 40 degrees F (-40 degrees C) (note that operation at –40 requires the "Arctic Nozzle" and "Arctic Hose" in the accessories section on page 11).
- Maximum Suction Lift: 10' (3 m) for gasoline; 18' (5.5 m) for diesel fuel (the lift in feet is equal to the vertical distance from the surface of the fluid in the tank to the inlet of the pump, PLUS friction losses through the vertical and horizontal runs of pipe, all elbows, and other fittings. System should be set up to require a **minimum** amount of suction lift).



IMPORTANT! All threaded connections on 700 series "M" suffix model pumps and meters are BSP standard threads, ***NOT*** NPT standard threads as described elsewhere in this manual. Be sure to check the model tag affixed to the motor to be certain which model pump you have.

ATTENTION!

The following information is for suffix “E” pumps and meters (designed for use in Europe, Australia, and New Zealand)! Refer to the information label applied to your pump to see if it is applicable.

FR700E

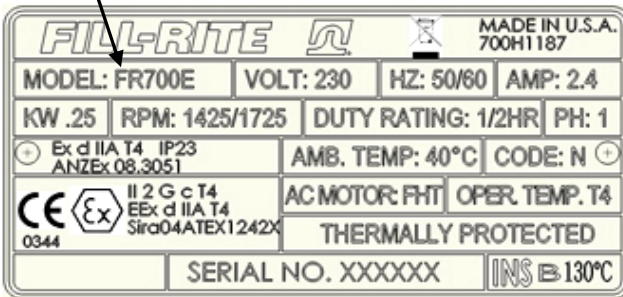

Materials of Construction

Materials of construction of the external surface of the unit are: painted steel; painted cast iron; painted aluminum; zinc plated steel.

Materials of construction of the wetted parts are: cast iron; steel; zinc plated steel; 300 series stainless steel; bronze; carbon; ceramic; polyester; fiber; fluorocarbon; buna; 400 series stainless steel; aluminum.

Repair and Maintenance

Contact the place of purchase for warranty repair and maintenance.

Special Conditions for Safe Use

The M8 fasteners used for securing the stator housing shall be Class 10.9. The M6 fasteners used for securing the terminal compartments cover shall be Class 8.8.

An electrically conductive hose and nozzle must be used with flammable liquids. To minimize static electricity buildup, keep nozzle in contact with container being filled.

Installation

Pump must be installed in compliance with EN 60079-14.

Certificates for Compliance of Safety have been obtained for the following agencies for products sold outside the US and Canada. Please refer to the tag on your particular product for its particular compliance data.



CENELEC standards.

