



LEADERS IN FLUID TRANSFER SOLUTIONS

Instruction Manual for 182130 Digital Grease Control Valve



 This manual contains important warnings and information.
Read and keep for reference.

Warning

Warning Symbol

 This symbol alerts you to the possibility of serious injury or death if you do not follow the instructions.

Caution Symbol

 **CAUTION** This symbol alerts you to the possibility of damage to or destruction of equipment if you do not follow the instructions.

Models

Item No.	Thread
18213010	1/4" BSP
18213030	1/4" NPT

Security

 Warning: Equipment misuse can cause the equipment to rupture or malfunction and result in serious injury even death.

 Equipment misuse hazard

Any misuse will lead to the damage, failure, rupture or malfunction of the equipment.

- This equipment is for professional use only.
- Read all instruction manuals, tags, and labels before operating the equipment.
- Use the equipment only for its intended purpose. If you are not sure, call your distributor.
- Do not alter or modify this equipment.
- Do not exceed the maximum working pressure of the lowest rated system component. This equipment has a 9000psi (60Mpa, 600bar) maximum working pressure.
- Check equipment daily. Repair or replace worn or damaged parts immediately.
- Handle hoses carefully. Do not pull on hoses to move the equipment.
- Route hose away from traffic areas, sharp edges, moving parts, and hot surfaces. Do not expose hoses to temperatures above 66°C (150°F) or below -40°C (-40°F).
- Comply with all application local, state, and national fire, electrical, and safety regulations.
- Do not use a low pressure flexible extension on a high pressure dispensing valve.
- Please wear hot-proof glove when use it.
- Do not move or aloft the equipment when use it.
- Do not attempt to force lubricant into a fitting.
- The operation environment must be fire-proof, safety electric use and other security assured.

 Injection hazard

Spray from the valve, leaks or ruptured components can inject fluid into your body and cause extremely serious injury, including the need for amputation. Fluid splashed in the eyes or on the skin can also cause serious injury.

- Fluid injected into the skin might look like just a cut, but it is a serious injury. Get immediate medical attention.
- Do not point the valve at anyone or at any part of the body.
- Do not put your hand or fingers over the grease fitting coupler.
- Do not stop or deflect leaks with your hand, body, glove or rag.
- Use control valve to dispense the grease in grease dispensing system.
- Tighten all fluid connections before operating the equipment.

- Check the hose, tubes, and couplings daily. Replace worn or damaged parts immediately. Do not repair high pressure couplings; you must replace the entire hose.

 Toxic fluid hazard

Hazardous fluid or toxic fumes can cause serious injury or death if splashed in the eyes or on the skin, inhaled, or swallowed.

- Know the specific hazards of the fluid you are using.
- Store hazardous fluid in an approved container. Dispose of the hazardous fluid according to all local, state and national guidelines.
- Always wear protective eyewear, gloves, clothing and respirator as recommended by the fluid and solvent manufacturer.

Pressure relief procedure

 Injection hazard

- Fluid under high pressure can be injected through the skin and cause serious injury.
- To reduce the risk of an injury from injection, splashing fluid, moving parts, or follow the pressure relief procedure whenever you are instructed to relieve the pressure, stop dispensing.
- Check or service any of the system equipment, or install or clean the nozzle.

To reduce the risk of serious bodily injury, including fluid injection, splashing in the eyes or on the skin, or injury from moving parts, always follow this procedure whenever you shut off the pump, and before inspecting, removing, cleaning or repairing any part the pump or system.

1. Close the supply pump's bleed-type master air valve (required in pneumatic systems).
2. Open the dispensing valve until pressure is fully relieved.
3. Open the fluid drain valve at the pump fluid outlet. Leave the drain valve open until you are ready to use the system again.

Notes:

If you suspect the dispensing valve, extension or grease fitting coupler is clogged, or that pressure has not been fully relieved after following all the previous steps, using a rag very slowly loosen the coupler or hose end coupling and allow pressure to be relieved gradually, then loosen the part completely. Now clear the clog.

Technique Parameter

Technique Parameter of Digital Grease Control Valve

Item Series No.	182130XX
Working Pressure	0.5-600bar
Working Temperature	Max. Temperature: 60°C

Installation and Operation

1 Installation

1.1 Typical Installation system pattern

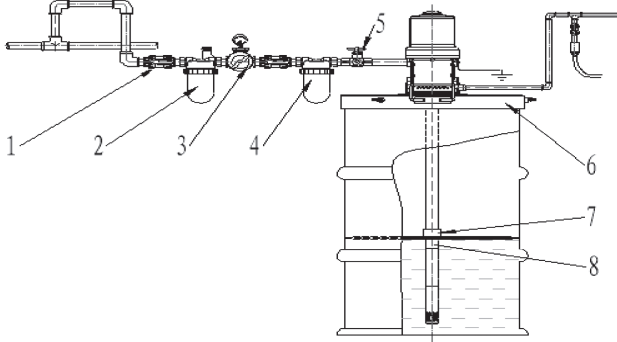

PICTURE 1

1: Check valve, 2: Filter, 3: Pressure regulator, 4: Lubricator
5: Control valve, 6: Drum cover, 7: Plate, 8: Grease pump

The installation is not complete grease lubrication system design, if you need help, please contact the manufacturer or the agent service.

1.2 Pre-installation process

1.2.1  **Warning:** To reduce the risk of serious injury, the pressure release should be concerned. Please refer to 3.2 for the release process.

1.2.2 Process

- Turn off the air check valve 1 as picture 1.
- Effective grounding to grease supply system. Don't use an insulation material to the ground. See 1.4 for the method for grounding.

1.3 The installation process for the digital grease control valve.

1.3.1  **Warning:** To reduce the risk of serious injury, pressure release should be concerned any time. Please refer to 3.2. for the release process

1.3.2 Installing the new grease control valve

- If you are a new user for the control valve, or valve used in grease supplying system appeared to be polluted. The cleaning work should be done before installation.
- The following steps are for a cleaning process
 - 1) Turn off the check valve of every dispensing point.
 - 2) Turn off the check valve of grease outlet.
 - 3) Turn off the check valve to decrease the air inlet pressure, then open it to make the grease pump in the working preparation.
 - 4) Slowly open the check valve of grease outlet.
 - 5) Hold the grease outlet to the waste tank to drain. If there are several draining place, drain the waste firstly from the furthest place, then the nearer place.

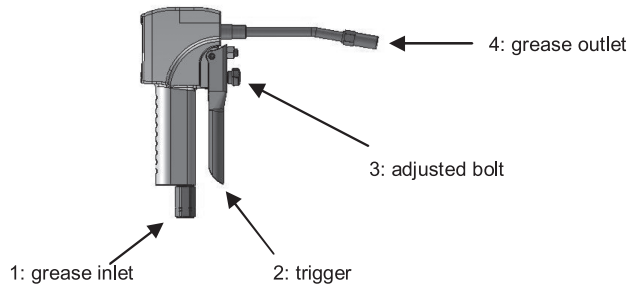

Picture 2: Grease Control Valve

- 6) Spread the sealing glue around the male thread of grease supplying system, connect it into the female thread of grease inlet, and then fix them together.
- 7) Turn on all check valves of grease system.
- 8) Handle the trigger to spray enough grease as reference to 3; make sure the grease system circle clean.
- 9) Repeat steps 6 to 8 for the other location of grease control valve.

1.3.3 Replace the grease control valve's installation

- Loose and take the replaced grease control valve off the system.
- Do the step 6 to 9. from 1.3.2 .

1.4. Grounding

1.4.1 The grounding is to maintain the security system.

1.4.2 To reduce static electricity, each unit of the system should carry out effective grounding.

- Control valve is done by manufacturers' recommendation.
- Air and fluid hoses need effective grounding too.
- Air compressor is done by manufacturers' recommendation.
- The grease barrels: effectively grounding
- Staying grounded is needed in the working and grease release process, especially the metal units are sure to be grounding before operating the control valve.

2 LCD Display

2.1 See the following displaying illustration of the LCD panel.

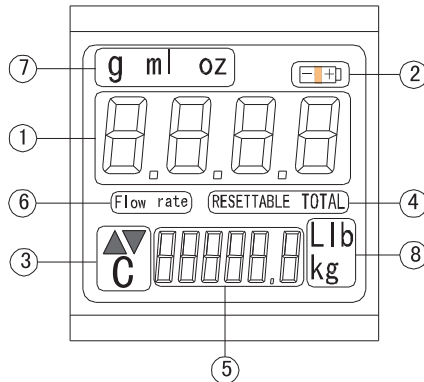

Figure 3: The LCD panel displays region

1 Section: 4 show the current flow range (0.1~999.9).

Measurement exceeds the maximum value will become zero and start re-measure.

2 Section: Battery condition (Full power or no power; If low power, alarm device will start)

3 Section: Model identification (Operation as the instructions, the arrow can be removed)

4 Section: The batch total can be reset and switched.

5 Section: 7 batch total can reset the total amount or value of total system (system total can not reset; the scope is 1 ~ 99999.9)

6 Section: Velocity model identifier

7 Section: The unit of measurement (g, ml, oz)

8 Section: The unit of total measurement (L, lb, kg)

2.2 Manipulation: Two keys, the left key pressed for the menu (sw2), the right one is to reset (sw1)

2.2.1 Unit set: press "sw1" and "sw2" key not exceed 5s to enter the unit set pattern; press "sw1" button to select the unit needed , then press "sw2" key not exceed 1s to quit the setting pattern, the digit blinks will stop.

2.2.2 To zero out: Press "sw1" button to display the screen about 1s, "0.0mL" appears or Unqualified.

2.2.3 Display: Press "sw1" and "sw2" button simultaneously to display the fixed parameter "1.000 " and total value, then down the key to restore "0.0mL".

2.2.4 Power alarm: Voltage below 2.6V., twinkle appears.

2.2.5 Automatically fixed coefficients: Press the "sw1" for 1s , the 1 section will display "0.00L", Use the standard grease pump to transfer until grease empty, 1 section digit will display "x.xxL"; Press "SW2" for more than 3S to enter the parameter setting model, then 1 section appear "00x.xxL"; Press "SW2" to revise the Digits, then press "SW1" to adjust the value appears—here input the size for standard barrel; then press " SW2" for more than 3S, exit to auto modification model, then the fixed coefficients are automatically generates.

2.2.6 The grease control valve to work in stable condition.

1) Press " SW1" to zero out

2) Aim the grease control valve at the container which size known, dispensing the grease until the grease more than two thirds of the container position. 1 section will display "xxxL";

3) To get the net weight of the container;

Press " SW2" more than 3S to enter the parameter setting model, 1 section

display "00xxxL"; Press "SW2" to select the digits, then press "SW1" to revise the digit value; Input the net weight of the grease, then press "SW2" more than 3S to exit the auto modification model, then the fixed coefficients are automatically generates.

- 4) Fixed coefficients : When 1 section display "0.00L", press "SW2"; 1 section will appear "1.0000" with the left digit flicker, click flicker to move the position to revise the coefficients, then press "SW1" to exit.

3 Operation

3.1  Warning: Before you release the trigger, the control valve is in the state of pressure. To reduce the pressure of high pressure flow from serious injuries, and the unexpected splash of the grease, when asked to 1) reduce pressure; 2) inspection, cleaning and maintenance of grease supplying system device; 3) before installation, adjustment of the grease control valve, the pressure should be released from the control valve. Please refer to 3.2

3.2 pressure release

- Stop the pump power.
- Put the control valve into the waste oil container, the grab the trigger to release pressure.
- Turn on the air valve and oil valve of the system
- Close the control valve.

3.3 When there is a question of

- 1) A problem of the control valve, connecting hose, and the grease outlet.
- 2) Pressure is not enough to release on the basis of these processes.
- 3) Pressure is released but very slowly, the grease supplying system should be cleaned to get rid of being blocked.

3.4  Warning: To reduce the serious bodily injury, It will never be allowed to work under the pressure more than the maximum working pressure.

3.5 Operation

3.5.1 Grab the trigger (refer to 2-2 part) position the control valve, then the control valve start to work.

3.5.2 Release the trigger, the control valve stop working.

3.6 The adjustment of flow rate: Rotating the nut 3 shown in picture 2 outside way, the free flow will be increased; Rotating the nut 3 shown in picture 2 inside way, the free flow will be decreased until there is no output.

Failure and Solution

F.1  Warning: To reduce the risk of serious injury, pressure release should be concerned, please refer to 3.2. for the release process.

F.2. Before checking and repairing the control valve, make sure the pressure should be released from the system and other devices

F.3 Battery replacement

F.3.1 When the LCD panel displays nothing or alarms from 2 section battery indication, the battery should be considered to be replaced.

F.3.2 Turn on the battery cover with opener.

F.3.3 Picked out of the two batteries :

F.3.4 Put the new batteries into it and the polar should be concerned.

F.3.5 Cover the battery

F.4 Cleaning the body cavity of control valve

F.4.1 when the control valve been shelved for a longer period of time or the grease output is very small, the body cavity of control valve should be cleaned.

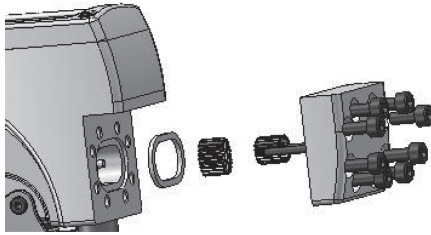

Figure 4

F.4.2 Use a wrench to rotate out of the hexagon screws from the valve body, see Figure 4;

F.4.3 Remove the front cover and the seal mat;

F.4.4 Take out of the two oval gears;

F.4.5 Clean the two oval gears with kerosene and ensure the gears without being damaged;

F.4.6 Clean the gear cavity with kerosene and make sure the kerosene should not splash onto the crystal display area;

F.4.7 Carefully put the seal mat up to the front cover;

F.4.8 Put the two ovals gear up to the two cylinders; rotate a gear to ensure the gear is move smoothly.

F.4.9 Carefully put it back the control valve body, then tighten the 8pcs of hexagon screws.

F.5 maintenance

F.5.1 All the parts should be checked as per the following steps to be disassembled, the worn or the damage shall not be used.

F.5.2 See the explosion chart to check every corresponding spare parts numbers.

F.5.3 Disassembling

F.5.3.1 Disassembling of grease outlet

- 1) Remove the grease coupler from the control valve;
- 2) Remove the grease hose 4;
- 3) Discharge the outlet valve.

F.5.3.2 Disassembling of trigger

- 1) Rotate out of the regulating hand wheel;
- 2) Rotate out of the hex nut 20;
- 3) Rotate the two hex bolts 27;
- 4) Discharge the trigger 17 and tapered spring 18.

F.5.3.3 Disassembling of circuit board

- 1) Rotate out of 4 pieces of hex bolt 27;
- 2) Remove the cover 2 and transparent board 8
- 3) Rotate out of the three screws 12 from the board; not to break the three wire of circuit board.

F.5.4 Assembling: Do the opposite step of the disassembling.

F.6 Troubleshooting Guide

Table 4: Troubleshooting Guide

Trouble	Reason	Solution
Grease leakage from trigger	Damage of top clubs 22 or steel ball 30	Replace top clubs or steel ball
Grease leakage from bottom	Loose connection 1	Re-tighten it
Grease leakage from the upper	Wear of sealing ring 25	Replace it
No working of the trigger	Hand round regulator 19 squeeze.	Adjust or replace it.
No displaying of crystal screen	Battery out of charge	Replace the battery.
Inadequate precision measurement	Loss of precision instrument	Refer to 2.2.5, re-set the fixed coefficient
	Air mixed into the grease	Adjust the working position of pump
Flow reduced or no output	Grease knot	Refer to F.4, clean the gear and body cavity.
Normal output but no measurement	Installation errors of oval gear after being cleaned	Re-installation
	Circuit board failure	Replace the circuit board
Trigger out but grease on outputting	Misplace of trigger	Adjust the trigger
	Offset positioning of steel ball	Re-assemble it.



F.7 Fatigue spare parts list

Table 5: Fatigue spare parts list of grease control valve.

Part No.	Description
6	Oval gear
13	Battery
16	O-ring
25	Seal mat
30	Steel ball
32	Washer
33	O-ring
34	O-ring
35	Washer

F.8 Other spare parts

Table 6: Other spare parts of grease control valve.

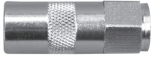
Description	Thread	Photo
1/4" Z Swivel	1/4" BSP	
	1/4" NPT	
Grease pipe	1/8" BSP	
	1/8" NPT	
Grease Coupler	1/8" BSP	
	1/8" NPT	

Others

1) Transportation

When the control valve in transit, It should be avoided direct sunlight, the rain, the falling, the erosive substance touched and being gathered.

2) Storage

1. Storage temperature: From -10°C to +40°C
2. The storage period is 6 months
3. The good ventilation assured in storage place and the directly sunlight be avoided.
4. Avoid the rain, the touch and gathering of the erosive substance, and 1m away from the heating device.

Limited Warranty

1. The manufacturer warrants this product against defects in material and craftsmanship, for a period of three years from date of purchase, but not including wearing parts.
2. Manufacturer's liability is limited to replacement or repair of defective material within the warranty period, when returned freight prepaid to the distributor or their designated service depot.
3. The warranty does not cover damage caused by accident, misuse or faulty installation.
4. The product must be installed and maintained in compliance with the instructions.



WARNING

Your risk from these exposures varies, depending on how often you do this type of work. To reduce your exposure to these chemicals: work in a well ventilated area, and work with approved safety equipment, such as those dust masks that are specially designed to filter out microscopic particles.

Exploded and Parts list

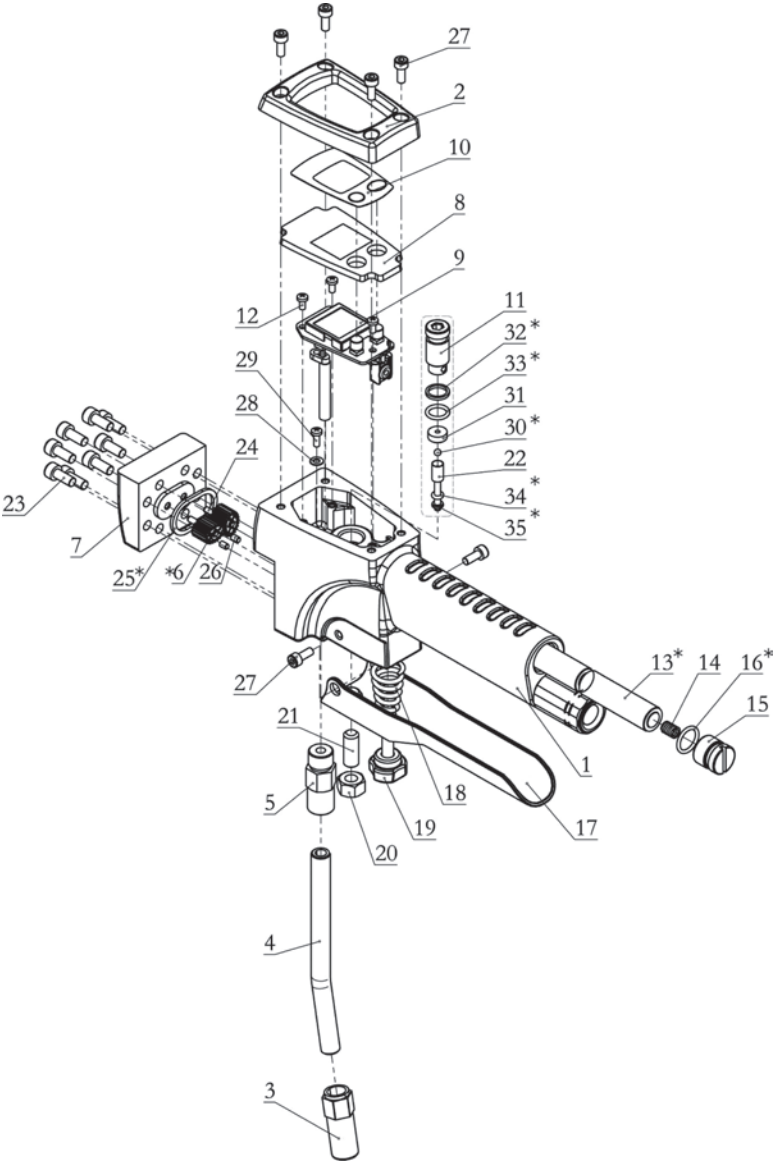

Part No.	Description	Q'ty	Part No.	Description	Q'ty
1	Control valve body	1	19	Adjust knob	1
2	Top cover	1	20	Nut	1
3	Coupler	1	21	Bolt	1
4	Rigid tube	1	22	Shaft	1
5	Outlet valve body	1	23	Bolt	8
6*	Gear	2	24	Pin	2
7	Front cover	1	25*	Seal	1
8	Lens	1	26	Magnetic stick	2
9	PCB assembly	1	27	Bolt	6
10	Label	1	28	Washer	1
11	Bolt	1	29	Screw	1
12	Screw	3	30*	Ball	1
13*	Battery	2	31	Valve cover	1
14	Spring	1	32*	Retainer	1
15	Battery cover	1	33*	O-ring	1
16*	O-ring	1	34*	O-ring	1
17	Trigger	1	35*	Retainer	2
18	Spring	1	36	Spring	1

Note: The Part No. with "*" are the wearing parts.