



LEADERS IN FLUID TRANSFER SOLUTIONS

HEAVY DUTY OIL PUMP MANUAL

DITI17130501



WARNING SYMBOL

- This manual contains important warnings and information
- Read and keep for reference

CAUTION SYMBOL

This symbol alerts you to the possibility of serious injury or death if you do not follow the instructions.

CAUTION

This symbol alerts you to the possibility of damage to or destruction of equipment if you do not follow the instructions.

1 Summarize

1.1 Mainly propose

-  These pumps mainly provide power during oil transportation. Any other use maybe cause un-safety problems and parts damage, fire explosion, and oil spark even serious fluid injection.

1.2 Description

1.2.1 Model: 3:1 Pneumatic Oil Pump

1.2.1.1 Specification: 36bar (Max. fluid working pressure)

1.2.1.2 Configuration:

Sheet 1: 3:1 Pneumatic Oil Pump

Model		17130301	17130303	17130331	17130333	17130361	17130363	17130371	17130373
Air inlet	1/4"quick plug	■		■		■		■	
	1/4"NPT		■		■		■		■
Length of suction tube	270mm	■	■						
	730mm			■	■				
	940mm					■	■		
	1190mm							■	■

Remark: with 3/4"M to 1/2"F reducer.

1.2.1.3 Max. free flow rate: 45L/min.

1.2.2 Model: 5:1 Pneumatic oil pump

1.2.2.1 Specification: 60bar (Max. fluid working pressure)

1.2.2.2 Configuration:

Sheet 2: 5:1 Pneumatic oil pump

Model		17130501	17130503	17130531	17130533	17130561	17130563	17130571	17130573
Air inlet	1/4"quick plug	■		■		■		■	
	1/4"NPT		■		■		■		■
Length of suction tube	270mm	■	■						
	730mm			■	■				
	940mm					■	■		
	1190mm							■	■

Remark: with 3/4"M to 1/2"F reducer.

1.2.2.3 Max. free flow rate: 40L/min.

1.2.3 Model: 9:1 Pneumatic oil pump

1.2.3.1 Specification: 108bar (Max. fluid working pressure)

1.2.3.2 Configuration:

Sheet 3: 9:1 Pneumatic oil pump

Model		17130901	17130903	17130931	17130933	17130961	17130963	17130971	17130973
Air inlet	1/4"quick plug	■		■		■		■	
	1/4"NPT		■		■		■		■
Length of suction tube	270mm	■	■						
	730mm			■	■				
	940mm					■	■		
	1190mm							■	■

Remark: with 3/4"M to 1/2"F reducer.

1.2.3.3 Max. free flow rate: 20L/min.

1.3 Safety instructions

1.3.1

⚠ WARNING: No complying with below requests will result in severely harm to your body even death.

1.3.2 Oil pump misuse hazard: Oil pump misuse can cause the to rupture, malfunction

- Read all instruction manuals, tags, and labels before operating the equipment
- Use the equipment only for its intended purpose. If you are not sure, call your distributor
- Do not alter or modify this equipment. Use only genuine parts and accessories
- Check equipment daily. Repair or replace worn or damaged parts immediately
- Do not exceed the maximum working pressure of the lowest rated component in your system
- Use fluids and solvents which are compatible with the equipment wetted parts. Refer to the Technical Data section of all equipment manuals. Read the fluid and solvent manufacturer's warnings.
- Do not use 1,1,1-trichloroethane, methylene chloride, other halogenated hydrocarbon solvents, or fluids containing such solvents in pressurized aluminum equipment. Such use could result in a chemical reaction, with the possibility of explosion.
- Handle hoses carefully. Do not pull on hoses to move equipment
- Route hoses away from traffic areas, sharp edges, moving parts, and hot surfaces
- Do not lift pressurized equipment
- Wear adiabatic glove when operate pump
- Do not move or lift pump during use
- Comply with all applicable local, state, and national fire, electrical, and safety regulations

1.3.3 SKIN INJECTION HAZARD

Fluid from the dispensing valve, leaks, or ruptured components can inject fluid into your body and cause extremely serious injury, including the need for amputation. Fluid splashed in the eyes or on the skin can also cause serious injury. If a fluid injection injury occurs, **GET IMMEDIATE SURGICAL TREATMENT. Do not treat as a simple cut.**

- Do not point the dispensing valve at anyone or at any part of the body
- Do not put your hand or fingers over the end of the dispensing valve
- Do not stop or deflect leaks with your hand, body, glove or rag
- Use only extensions and no-drip tips which are designed for use with your dispensing valve
- Do not use a low pressure flexible nozzle with this equipment
- Follow the Pressure Relief Procedure if the dispensing valve clogs before you clean, check o service the equipment.
- Tighten all fluid connections before operating the equipment
- Check the hoses, tubes, and couplings daily. Replace worn or damaged parts immediately
- Do not repair high pressure couplings; you must replace the entire hose

1.3.4 MOVING PARTS HAZARD

Moving parts can pinch or amputate your fingers.

- Do not operate the pump with the air motor plates removed
- Keep clear of all moving parts when starting or operating the pump
- Before servicing the equipment, follow the Pressure Relief Procedure to prevent the equipment from starting unexpectedly.

1.3.5 FIRE AND EXPLOSION HAZARD

Improper grounding, poor ventilation, open flames or sparks can cause a hazardous condition and result in a fire or explosion and serious injury.

- Ground the equipment and the object being lubricated
- If there is any static sparking or you feel an electric shock while using this equipment, stop dispensing immediately. Do not use the equipment until you identify and correct the problem.
- Provide fresh air ventilation to avoid the buildup of flammable fumes from solvents or the fluid dispensed
- Keep the dispensing area free of debris, including solvent, rags, and gasoline
- Do not smoke in the dispensing area

2 Technical Data

Pneumatic Oil Pumps Technical Data:

Model Series	171303 Series	171305 Series	171309 Series
Pressure Ratio	3:1	5:1	9:1
Air Inlet Working Pressure	5-10 bar		
Max. Air Inlet Pressure	12 bar		
Max. Oil Outlet Pressure	36 bar	60bar	108bar
Air Motor Effective Diameter	108mm		
Max. Free Flow Rate	45L/min	40L/min	20L/min

3 Grounding and Installation

3.1 Grounding

3.1.1 Warning: Before use the pump, check grounding of the whole system to prevent fire and explosion

3.1.2 To reduce the risk of static sparking, each device should ground effectively.

Pump: Use a ground wire and clamp as the Fig.2. Get rid of the grounding screw, put the end of the grounding wire into the grounding hole. Lock the bolt to the pump safety.

Air and Fluid hoses: Grounding effectively.

Air compressor: Follow manufacturer's recommendations.

Oil control valve: Connect the pump with proper grounding wire, always hold a metal part of the valve firmly to the side of a grounded metal pail, then trigger the valve.

Barrel: Use local applicable trolley. If it is metal barrel, put on the device which is electric, can not put on insulative device surface, such as paper or carton board which without grounding.

Other parts: Operated with local regulation for grounding.

Fluid supply container: Follow the local code.

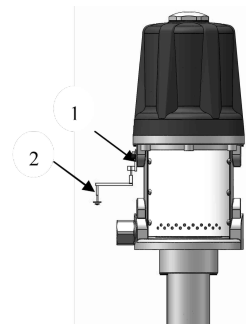

FIG.2: Grounding guide

3.2 Installation

3.2.1 Standard installation

- 1: cut-off valve
- 2: Filter
- 3: Regulator
- 4: Lubricator
- 5: Control valve
- 6: Locking adapter
- 7: Hose reel

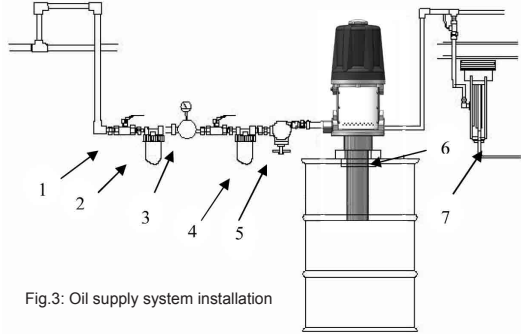

Fig.3: Oil supply system installation

The above installation is not the integrated oil supply system, just contact the manufacture or distributor if you need. Installation for air circle.

3.2.1.1 Note: Do not hang any device at the air inlet, as there maybe dropping and damage.

3.2.1.2 Process

- Put the pump into lock adapter (Fig .3 Parts 6), Install to the trolley.
- Install cut-off valve (Fig3. Part1).
- Install filter (Fig 3. Part 2).
- Install regulator which control the speed and adjust the air pressure (Fig3. Part3).
- Install lubricator which with self-lubricate (Fig3. Part 4).
- Install control valve which control flux, When the speed is too fast, pump will be self-close automatic to avoid pump be damaged (Fig.3 Parts5).
- Connect oil output.

3.3 Operation

3.3.1 Pressure Relief

3.3.1.1 Injury for skin: Before pressure relief by manual, Pump is under pressure. To reduce the risk of serious injury from pressurized fluid, accidental spray from the valve, or splashing fluid, follow this procedure whenever you

- Are instructed to relieve pressur
- Stop dispensin
- Check, clean, or service any system equipmen
- Install or clean dispensing device

3.3.1.2 Pressure Relief procedure

- Turn off the cut-off valve, shut off ai
- Put the pump to the waste equipments, switch oil valve ,relief pressur
- Turn the air supply and oil fluid
- Turn off the oil valve

3.3.1.3. When occurs:

- Problems on control valve, flexible hose, rigid tube or manual tip, auto tip.
- Pressure not relieve thoroughly according to above relief procedure.
- Pressure relieved very slowly until relieved thoroughly. Please clear obstruction of oil system.

3.3.2 Operation

3.3.2.1 Note: After initialize work, open the oil valve, pump start to work. Close the oil valve, pump stop working.

3.3.2.2

⚠ WARNING: Each device with different max working pressure. To reduce the risk of exceed pressure. Make sure the max work pressure for each device. Rated pressure in the system can not exceed the max pressure of any device. Or there will be burst, explosion, malfunction, serious damage.

3.3.2.3 Remind: Pump can not operate with empty load. Or the speed will be very fast which will self-damage.

If acceleration is too fast or running very slow, Should stop operation and check that if there is enough oil in the barrel. If there is insufficient oil, change the trolley and initialize the whole system.

3.3.2.4 Startup

- If there is several pump in the whole system, please use control valve to dispatch the air
- Open the main control valve
- Open the oil valve which with effective grounding with the trolley. Keep the connecting of th metal forboth oil valve and trolley. Open the cut-off valve, pump start to work. When the pump is stable. Close theoil valve.
- If there are several pumps in the whole system, startup for each pump step by step with abov instruction.
- To get perfect result, set up the min air pressure for each device
- Pump can not operate under empty load
- Relief pressure before close the pump

4 Trouble Shooting



WARNING:

To reduce the risk of serious injury whenever you are instructed to relieve pressure. Do not remove silencer, or it may cause finger be injury.

4.1 Before check and maintain, pay more attention of the relieve of pressure.

4.2 Ordinary problems, reason and solution

Problem	Cause	Solution
Pump fails to operate	Inadequate air supply pressure or restricted air lines	Increase air supply; clear
	Closed or clogged dispensing valve	Open; clear
	Clogged fluid lines, hoses, valves, etc	Clear
	Damaged air motor	Service air motor
	Exhausted fluid supply	Refill and re-prime or flush
Continuous air exhaust	Worn or damaged air motor gas-kit, packing, seal, etc.	Service air motor
Erratic pump operation	Exhausted fluid supply	Refill and re-prime or flush
	Held open or worn intake valve or piston packing	Clear; service
	Hose damaged	Change hose
Pump operates, but output low on both strokes	Piston damaged	Change piston
	Seal O-ring damaged	Change O-ring
	Hose, valve or other device block	Relieve pressure
Leakage from silencer	O-ring damaged	Change O-ring

Exploded and Parts List for 171303 Series

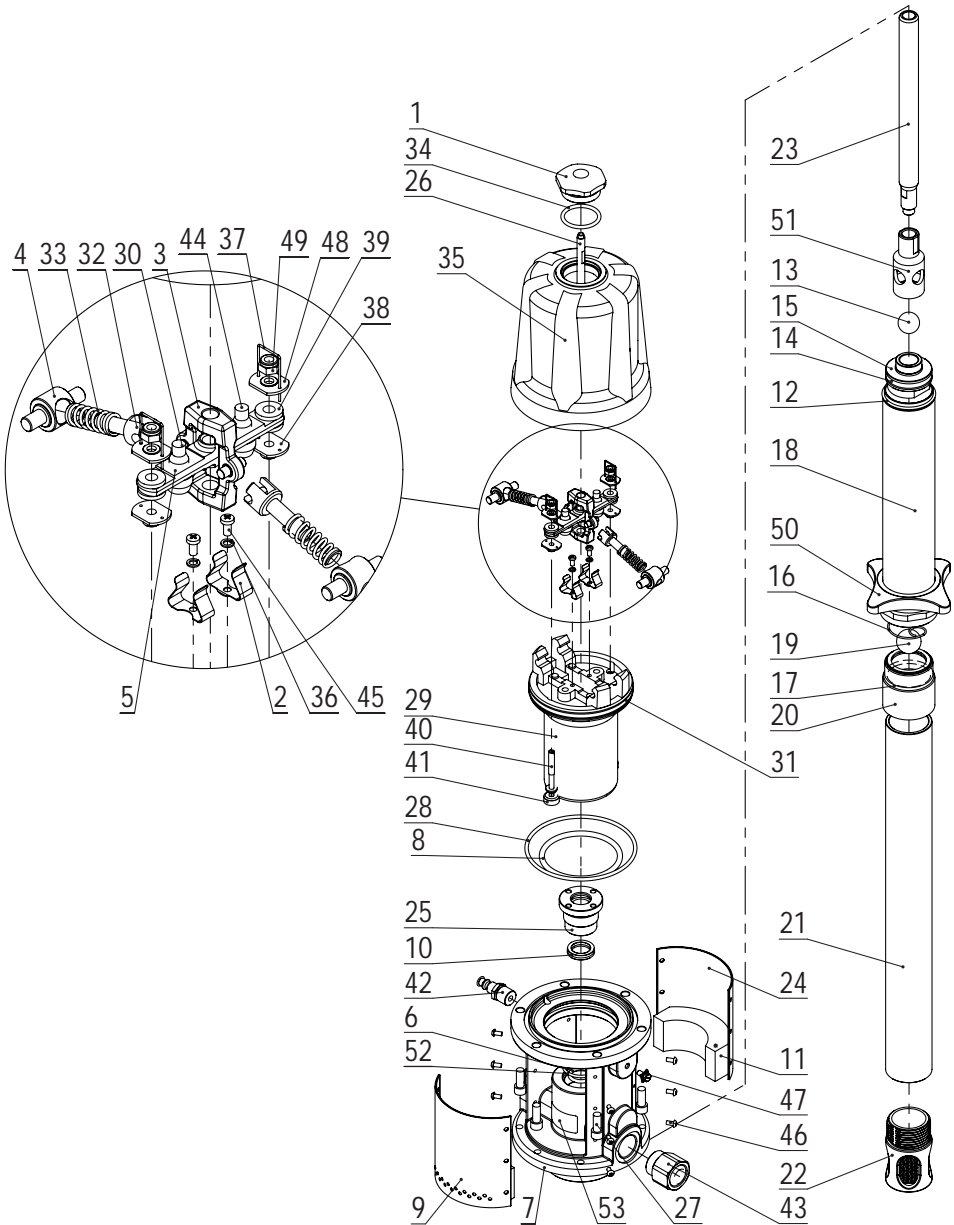

Part No.	Description	QTY	Part No.	Description	QTY
1	Air motor cover	1	28*	O-ring	1
2*	Spring piece	2	29	Piston	1
3	Bracket	1	30	Pin	2
4	Rope rocker	2	31*	O-ring	1
5	Shaft	1	32	Rope shaft	2
6*	O-ring	1	33*	Spring	2
7	Base	1	34*	O-ring	1
8*	O-ring	1	35	Jar body	1
9	Right silencer	1	36	Washer	2
10*	U-se	1	37*	Steel wire	2
11*	Sponge	2	38	Nut	4
12*	O-ring	1	39*	Cushion	2
13	Steel ball	1	40	Rod	2
14*	O-ring	1	41*	Seal	2
15	Piston	1	42	Quick plug	1
16*	Circlip	1	43	Oil outlet	1
17*	O-ring	1	44*	Gasket	2
18	Suction tube	1	45	Screw	2
19	Steel ball	1	46	Screw	12
20	Oil inlet valve	1	47	Bolt	1
21	Extension tube	1	48	Adjustable nut	2
22*	Filter	1	49	Nut	2
23	Piston shaft	1	50	Bung adapter	1
24	Left silencer	1	51	Connect tube	1
25	Transfer slipcover	1	52*	O-ring	1
26	Rod	1	53	Label	2
27	Screw	6			1

Note: The Part No. with "*" are the wearing parts.

Exploded and Parts List for 171305 & 171309 Series

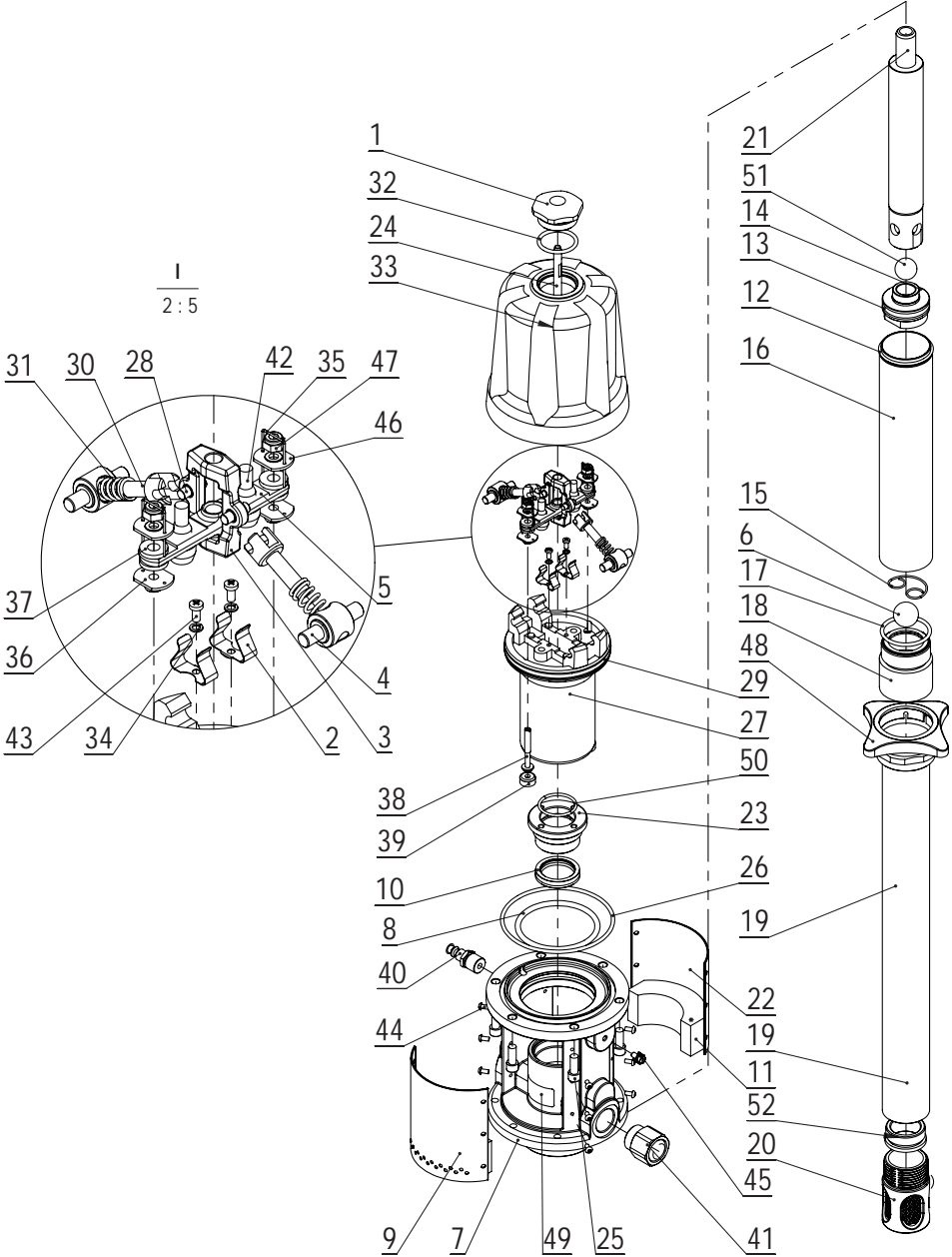

Part No.	Description	QTY	Part No.	Description	QTY
1	Air motor cover	1	27	Piston	1
2*	Spring piece	2	28	Pin	2
3	Bracket	1	29*	O-ring	1
4	Rope rocker	2	30	Rope shaft	2
5	Shaft	1	31*	Spring	2
6*	Steel ball	1	32*	O-ring	1
7	Base	1	33	Jar body	1
8*	O-ring	1	34	Washer	2
9	Right silencer	1	35*	Steel wire	2
10*	U-seal	1	36	Nut	2
11*	Sponge	2	37*	Cushion	2
12*	O-ring	1	38	Rod	2
13*	O-ring	1	39*	Seal	2
14	Piston	1	40	Quick plug	1
15*	Circlip	1	41	Oil outlet	1
16	Suction tube	1	42*	Gasket	2
17*	O-ring	1	43	Screw	2
18	Oil inlet valve	1	44	Screw	12
19	Extension tube	1	45	Bolt	1
20*	Filter	1	46	Adjustable nut	2
21	Piston shaft	1	47	Nut	2
22	Left silencer	1	48	Bung adapter	1
23	Transfer slipcover	1	49	Label	2
24	Rod	1	50*	O-ring	1
25	Screw	6	51	Steel ball	1
26*	O-ring	1	52	Connector (only use for 171309)	1

Note: The Part No. with “*” are the wearing parts.

Wall Installed Part List

Part No.	Description	Q'ty
1	Oil Pump	1
2	Bolt	6
3	Nut	6
4	Wall bracket	1
5	Pump adapter	1
6	Flexible suction hose	1
7	Bung adapter	1
8	Rigid suction tube	1
9	Spring circlip	1
10	Ball	1
11	Valve seat	1
12	Filter	1
13	Washer	6
14	Washer	6
15	Suction hose adapter	1

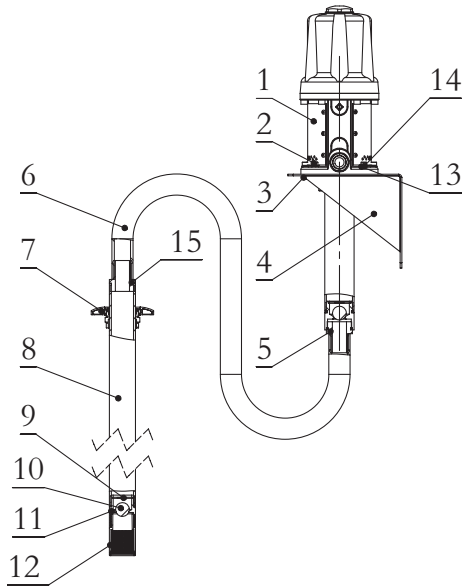

Proceed As Follows

1. Secure the bracket to the wall using the dowels at about 1200mm height appropriate for the tank's dimensions. Make sure that the wall is solid and thick enough for the dowels. Do not interfere with hydraulic tubes or electric lines.
2. Secure the pump to the bracket
3. Connect the flexible suction tubes 6 to the pump using the clamp provided
4. Connect the rigid suction 8 to the end of the flexible suction tube 6 using the elastic clamp provided.
5. Put the bung adapter 7 into the drum hole
6. Put the rigid suction tube 8 into the pump and secure it in place

Limited Warranty

1. The manufacturer warrants this product against defects in material and craftsmanship, for a period of 36 months from date of purchase, but not including wearing parts.
2. Manufacturer's liability is limited to replacement or repair of defective material within the warranty period, when returned freight prepaid to the distributor or their designated service depot.
3. The warranty does not cover damage caused by accident, misuse or faulty installation.
4. The product must be installed and maintained in compliance with the instructions.