



LEADERS IN FLUID TRANSFER SOLUTIONS

INSTRUCTIONS MANUAL

240Volt Diesel Cabinet Pump DAF3000 Series



MAIN COMPONENTS

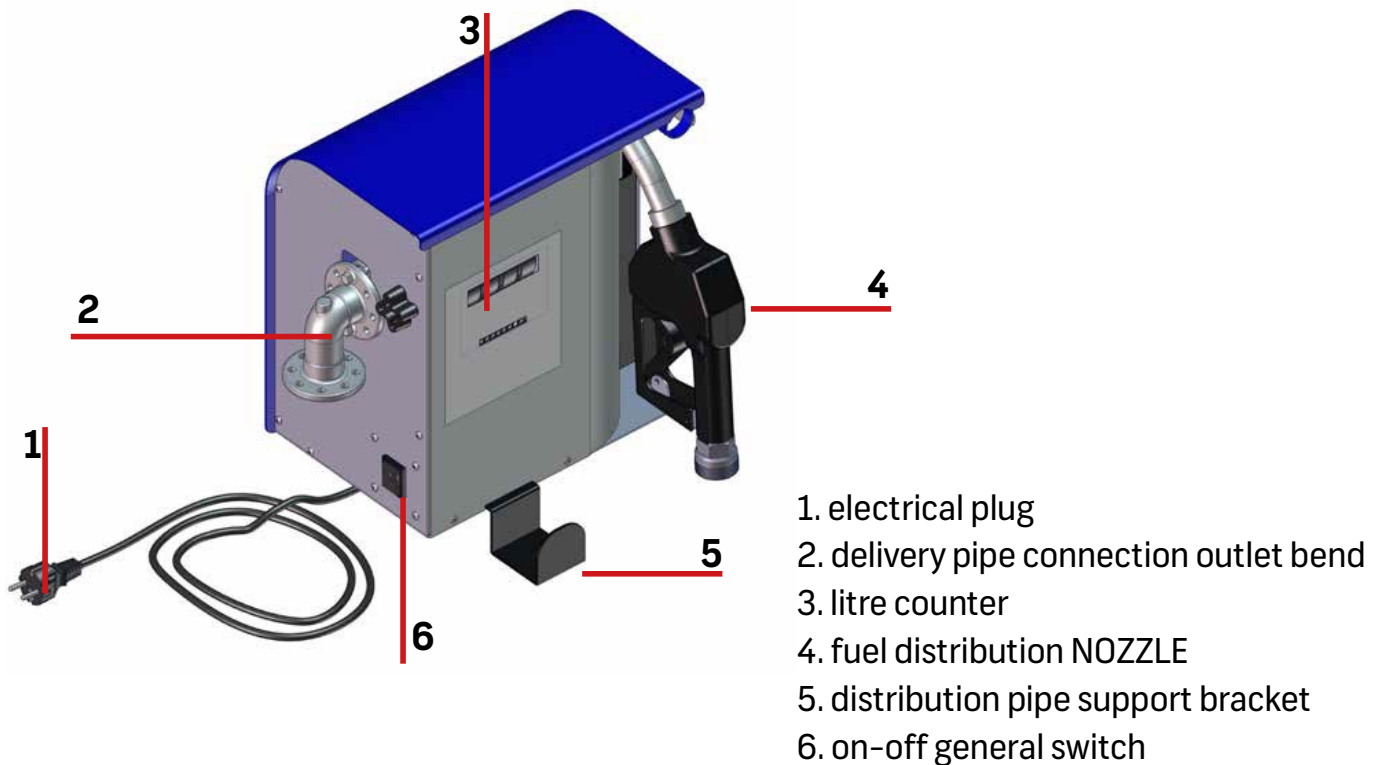

MANUFACTURING CHARACTERISTICS OF THE MOTOR:

Self-ventilated closed electrical motor with IP 55 protection, insulation class F.

MANUFACTURING CHARACTERISTICS OF THE PUMP:

Pump body: G 25 CAST IRON

Motor support: ALUMINIUM

Impeller: SYNTERED IRON

Motor shaft: C 40 STEEL

Reducer: ALUMINIUM

ELECTROMAGNETIC ENVIRONMENT

The machine is manufactured to operate correctly in an electromagnetic environment of the industrial type, meeting the limits of Emission and Immunity, envisaged by the following Harmonised Standards:

CEI EN 61000-6-2 Electromagnetic compatibility (EMC) General Standards -
Immunity for industrial environments

CEI EN 61000-6-4 Electromagnetic compatibility (EMC) General Standards -
Emission for industrial environments

OPERATION PROBLEMS

PROBLEMS	POSSIBILI CAUSES	SOLUTIONS
The pump does not start	<ol style="list-style-type: none"> 1. Problems on the suction part 2. By pass valve open 3. Blades blocked 4. Leak from the gaskets 5. Excessive wear of the impeller and blades 6. Blocked overflow 	<ol style="list-style-type: none"> 1. Check that there are no leaks in the suction part 2. Check and clean the valve: it must move freely 3. Check and clean the blades and the housings: they could be worn, dented or dirty 4. Tighten further the covers and the joints: they could be loose 5. Check the impeller and the blades: they could be too worn 6. Check the pump outlets, the pipe , the NOZZLE and also the filter
The pump vibrates but does not operate	<ol style="list-style-type: none"> 1. Dirt in the hollows of the pump 2. Defective motor 3. Broken key of motor 	<ol style="list-style-type: none"> 1. Clean these hollows 2. Contact the seller 3. Remove the debris and substitute the key
Low delivery problems	<ol style="list-style-type: none"> 1. Too much dirt in the filters 2. Problem of the suction part 3. Blocked by pass valve 4. Blocked blades 5. Excessive wear of the blades and the impeller 6. Damaged pipe or distribution NOZZLE 7. Closed filter 8. Level of liquid in the tank low 	<ol style="list-style-type: none"> 1. Clean the filters 2. Check that there are no limitations or leaks in the suction part: it could be too small, too long or not sealing any longer 3. Check state of valve 4. Check the blades and their housings 5. Check state of blades and impeller 6. Substitute pipe or NOZZLE 7. Substitute the filter 8. Fill up the tank
The pump rotates slowly	<ol style="list-style-type: none"> 1. Incorrect voltage 2. Blocked blades 3. Problems at electric contacts 4. Problems at the motor 	<ol style="list-style-type: none"> 1. Check the electrical plant while the pump is in operation 2. Check the blades and the housings 3. Check that the contacts are not loose 4. Contact the seller
Power loss of the motor	<ol style="list-style-type: none"> 1. Blocked by pass valve 2. Low voltage 3. Excessive wear of the impeller or of the blades 4. Debris in the hollow of the pump 	<ol style="list-style-type: none"> 1. Check the state of the valve 2. Check the current of the plant while the pump is in operation 3. Check the state of the blades' impeller 4. Clean the pump hollows

PROBLEMS	POSSIBILI CAUSES	SOLUTIONS
The motor overheats	<ol style="list-style-type: none"> 1. The used liquid has a very high viscosity 2. Obstructed filters 3. Suction pipe either dirty or obstructed 4. Faulty motor 5. Blocked pump impeller 	<ol style="list-style-type: none"> 1. Must transfer for small periods of time, certainly much less than 30 minutes of the max cycle. 2. Clean the filters 3. Clean suction pipe 4. Contact the seller 5. Check and clean impeller and impeller chamber
The motor does not start	<ol style="list-style-type: none"> 1. No current 2. Defective interruption 3. Defective motor 4. Defective technical protections 5. Defective or loosened electrical components 	<ol style="list-style-type: none"> 1. Check its electrical network 2. Contact the dealer 3. - 4. - 5. Check the electrical contacts
Loss of liquids	<ol style="list-style-type: none"> 1. Ruined OR gaskets 2. Dirty shaft seal ring 3. Ruined shaft seal ring 4. Not compatible liquids 5. Loss of tightening 	<ol style="list-style-type: none"> 1. Check the state of all the OR gaskets 2. Clean the seal ring and its seat 3. Substitute the seal ring 4. Ask your supplier for the composition of the liquid 5. Tighten all screws

EXTRAORDINARY MAINTENANCE

GENERAL PROVISIONS

It is recommended to stop and take action with the extraordinary maintenance whenever a not optimal operation is detected; this will allow always having the maximum efficiency.

Always use the special P.P.E. – Personal Protective Equipment:

- Gloves
- Non-slip shoes
- Goggles
- Mask
- Suitable clothing

CLEANING OF FILTER

- ⚠ Make sure that the pump is disconnected from the electrical current and that it is not in operation

1. Unscrew the screws that hold tight the front part of the metal sheet and open the distributor;

①



②



③



2. Identify the filter to be cleaned in the lower part on the right of the pump and unscrew the plug;

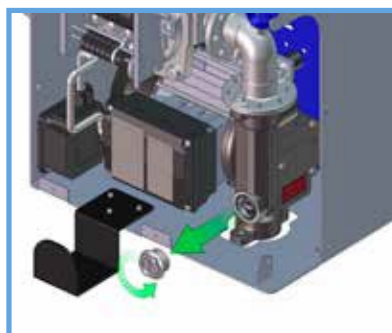
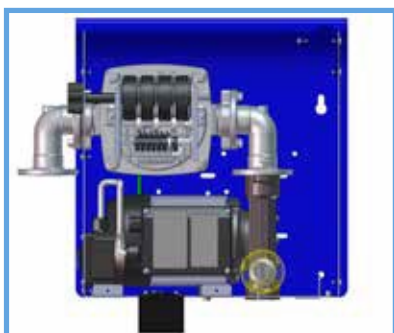

3. Extract the filter, clean it and screw back its plug;

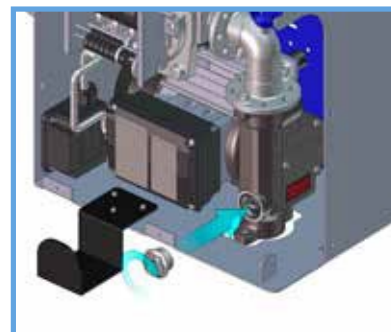
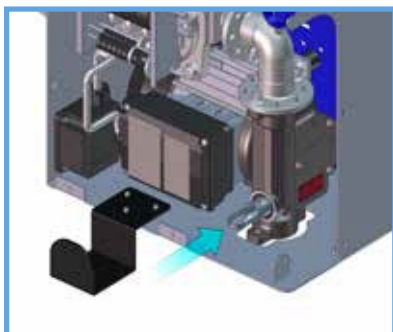
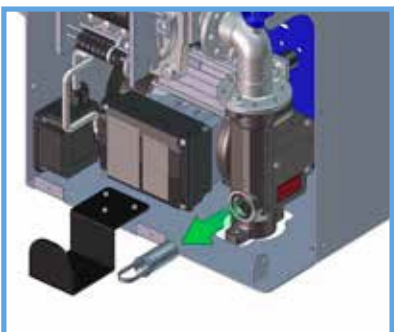

4. Replace in the original position the front metal sheet and screw back all seven screws.



CALIBRATION OF THE MECHANICAL LITRE COUNTER

Calibration is necessary when the litre counter is new, after dismounting, when a different fluid is measured or as consequence of significant wear. Calibration of the litre counter can be changed easily by following the calibration procedure listed below. For the calibration procedure it is necessary a test container or a container of KNOWN volume. It is recommended that the container has a volume of at least 19 litres (5 gallons).

CALIBRATION PROCEDURE

1. Follow Figures 1-3 (as for cleaning of the filter, page 5) to access to the calibration screw;
2. Fill the container up to a known volume;
3. if the indicated quantity does not correspond to the known volume, the litre counter must be calibrated. Make sure that the pump is closed and that the pressure is interrupted, hence remove the sealing screws and rotate the calibration screw (Fig. A) in the anticlockwise direction to reduce the indicated quantity, or in the clockwise direction to increase this quantity. A full rotation changes the indicated quantity by about 0.4 of a litre. Reinstall the sealing screw;
4. Repeat point 2 until the calibration is acceptable.

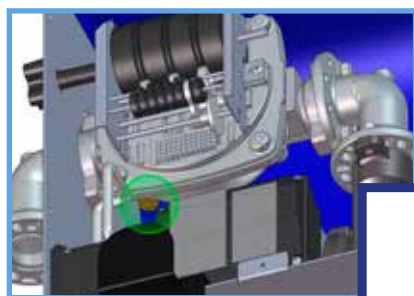
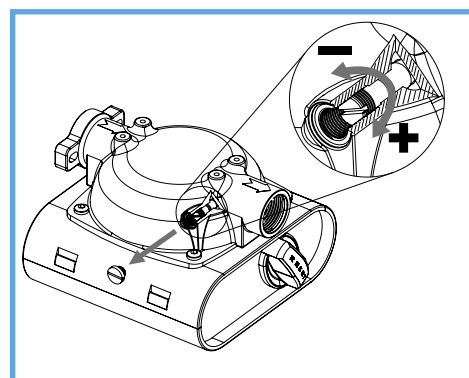
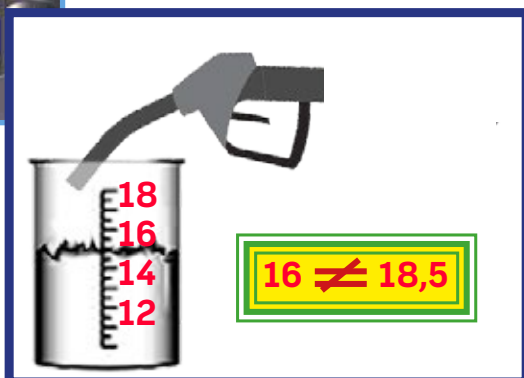



Fig. A



 Non compliance of what is requested, exempts the manufacturer from any liability to the effects of the guarantee

ASSISTANCE

The manufacturer may always be deemed at disposal for any type of information relating to installation, use and maintenance of the machine.

On the Customer's side, it is appropriate to ask the questions clearly, making reference to this Manual and to the listed instructions.

SPARE PARTS



Always use original spare parts.
For any spare parts contact us

Use of not original spare parts is not recommended: in the event that this occurs, the conditions of Guarantee will be void (if still valid) and so will be the liability of the Manufacturer with respect to the use of the machine and for any possible damages to persons and/or things.

List of spare parts DAF3000 (mechanical)

POS.	DESCRIPTION	60L	80L	100L	QTY
1	DAF3000 - BLUE HI-TECH PANEL		HT013		1
2	DAF 3000 PUMP BASE METAL SHEET		AF023		1
3	FRONT CLOSING METAL SHEET		AF025		1
4	DAF 3000 NOZZLE HOLDER		AF019		1
5	DAF 3000 PIPE HOLDER		AF024		1
6	230V PA PUMP	PA7000	PA8000	PA1007	1
7	MECHANICAL LITRE COUNTER		TF4CS1		1
8	AUTOMATIC NOZZLE*	2715010000000	AU0901N	27150300	1
9	4C NEUTRAL MASK		MA060		1
10	M8x16 ISO 4162 TE FR SCREW		VT005		6
11	1" BSP-G WORKED TELEPHONE		HT008L		1
12	ANNULAR GASKET		OR017		1
13	KNOB FOR KM4		71000532		1
14	M4x10 CROSS TC SCREW		80901439100		1
15	M4 X 16 ISO7045 CROSS TC SCREW		VT014		4
16	SWITCH		190050210000		1
17	TERMINAL BOX COVER GASKET__		OR022		1
18	TERMINAL BOX COVER		PA003		1
19	GLAND PLATE		PA004		1
20	M4 UNI5588 NUT		VT015		4
21	d31 THREAD SAVE PLUG		163013500000		2
22	RAW TELEPHONE		HT008		1
23	37 x 3 NBR O-RING		OR011		2
24	M6x14 ISO 4017 TE SCREW		80232320100		1
25	EARTHING CABLE		CA004		1
26	WASHER		83102310000		1
27	DAF3000 LITRE COUNTER SUPPORT		AF022		1
28	M5x8 TCCE SCREW		VT002		1
29	DAMPER		17001106		4
30	M6x10 uni 5739 TE SCREW		80202313100		1
31	M5x8 ISO 7045 TC CROSS SCREW		81011810100		3
32	M6 ISO 4161 FLANGED NUT		71000112		4
33	M4x10 TC CROSS SCREW		80901439100		16

* rotating, included in all versions

Exploded DAF3000 (mechanical)

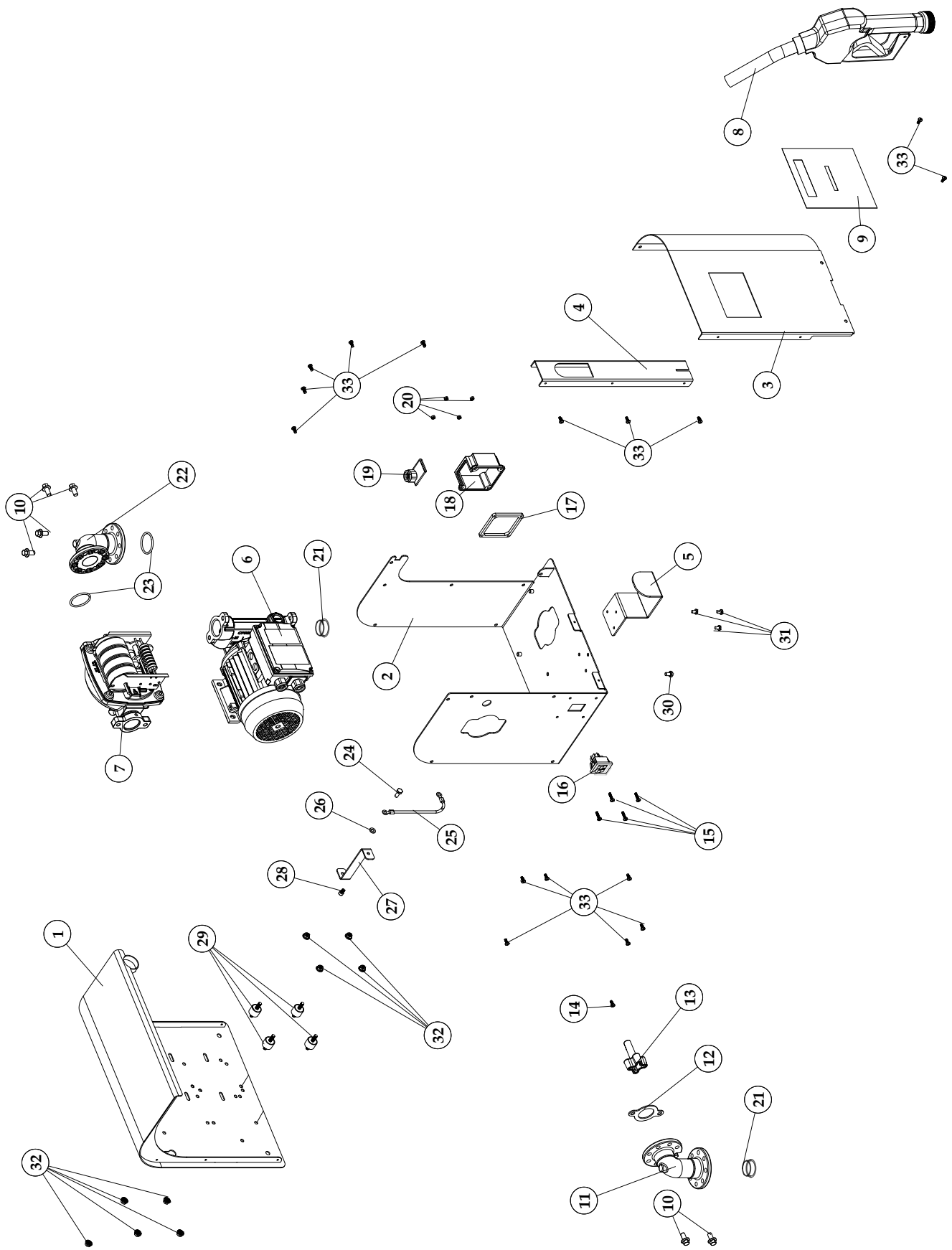

TECHNICAL SHEET DIMENSIONS

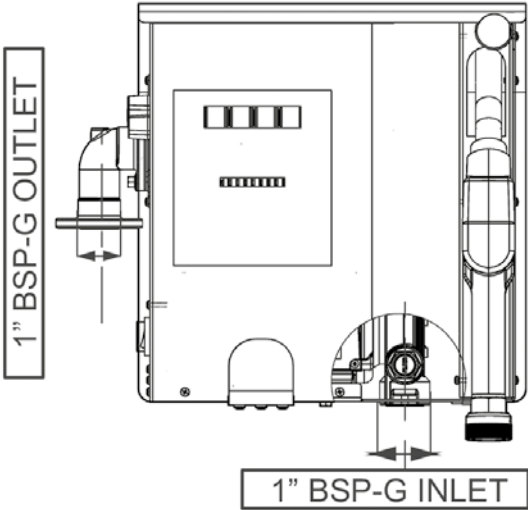
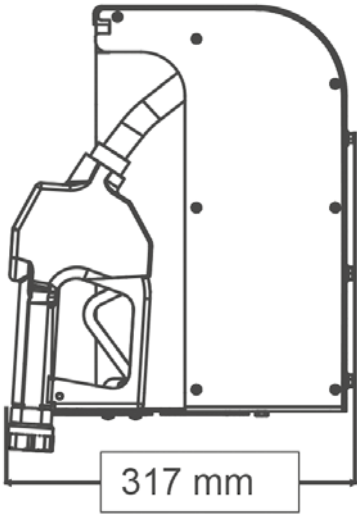
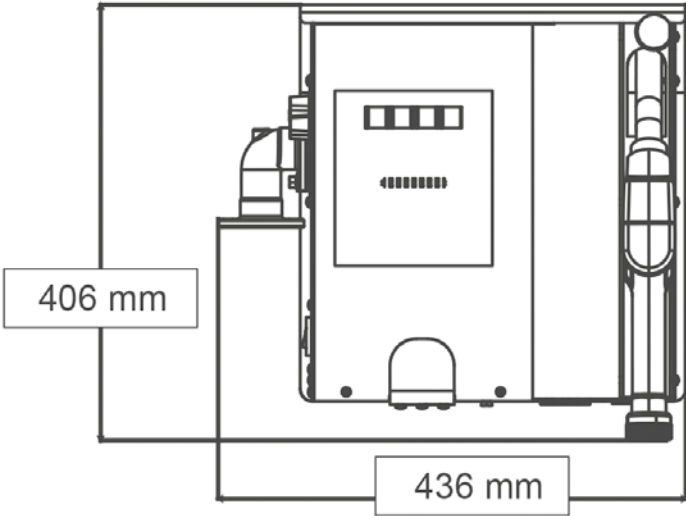

CIRCUIT DIAGRAM

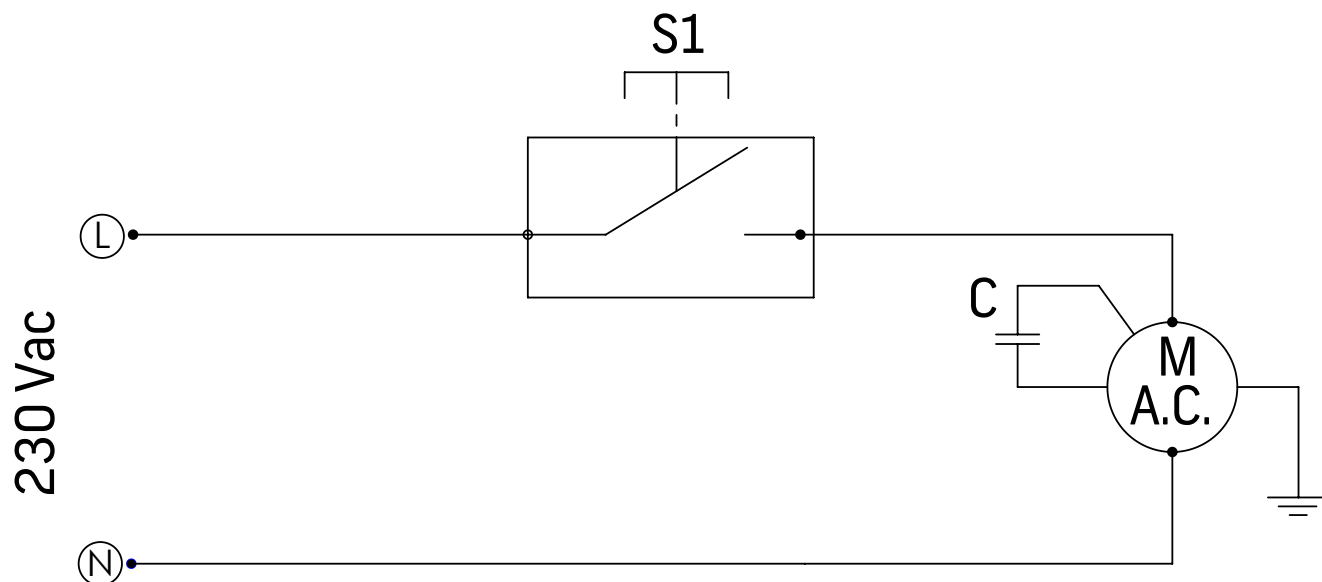

S1 : Interruttore ON - OFF
M : Motore
C : Condensatore

*) Distributori serie AF3000 e AF1